

INSTALLATION, OPERATING AND SERVICE INSTRUCTIONS CG-D™ SERIES GAS BOILER

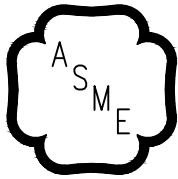

H



BEFORE INSTALLATION: READ THIS MANUAL

SAVE THESE INSTRUCTIONS

Installing contractor and homeowner should read and be informed as to the proper installation and operation of this boiler. The manufacturer will not be responsible for improper installation or operation. This manual and all associated instruction material should be conspicuously posted near the boiler.

For service or repairs to boiler, call your heating contractor. When seeking information on boiler, provide Boiler Model Number and Serial Number as shown on Rating Label.

Boiler Model Number CG D	Boiler Serial Number	Installation Date
Heating Contractor		Phone Number
Address		



New Yorker[®]
RESIDENTIAL HEATING BOILERS

The following terms are used throughout this manual to bring attention to the presence of hazards of various risk levels, or to important information concerning product life.

DANGER

Indicates an imminently hazardous situation which, if not avoided, will result in death, serious injury or substantial property damage.

CAUTION

Indicates a potentially hazardous situation which, if not avoided, may result in moderate or minor injury or property damage.

WARNING

Indicates a potentially hazardous situation which, if not avoided, could result in death, serious injury or substantial property damage.

NOTICE

Indicates special instructions on installation, operation, or maintenance which are important but not related to personal injury hazards.

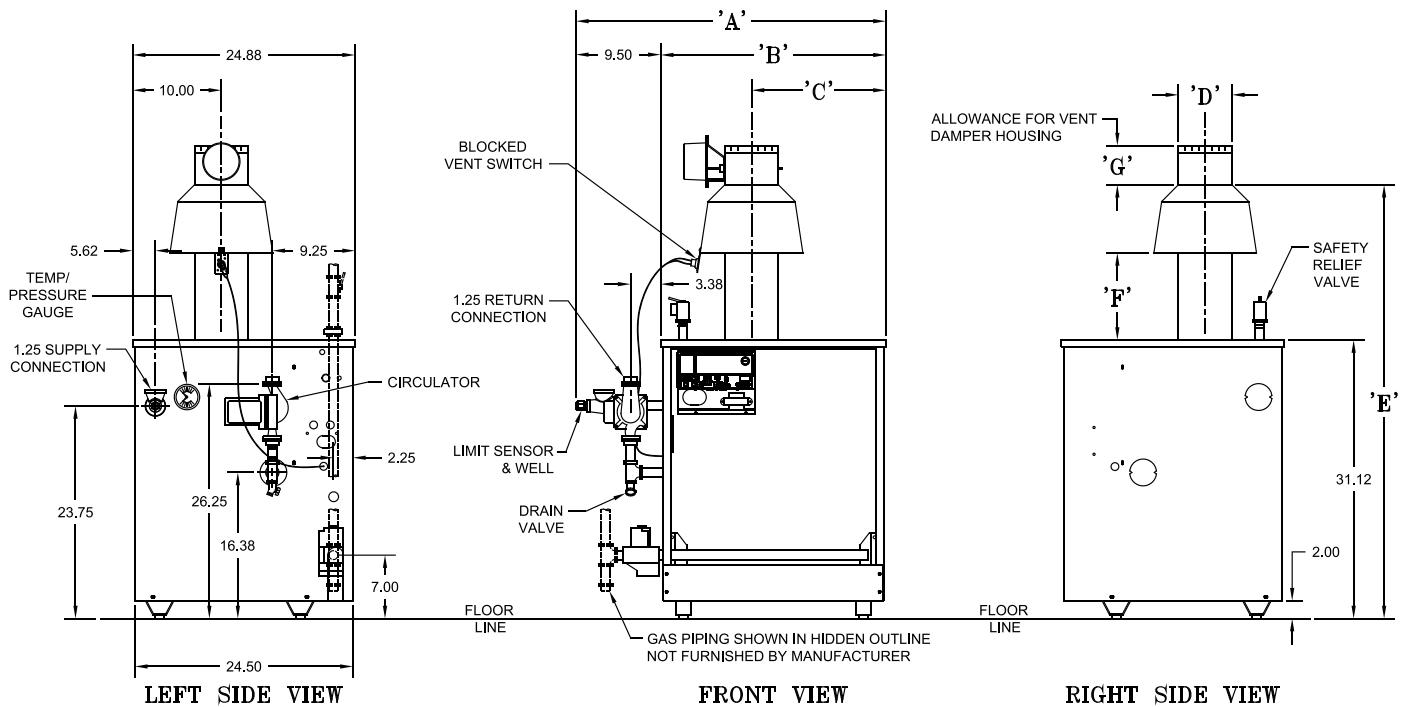

Figure 1: Dimensional Drawing

Table 1: Dimensional Data

Boiler Size	Dimensions [Inches]							Recommended Vent Size [2]	Gas Connection [FPT]	Water Content [gallons]	Approx. Shipping Weight [lb.]
	'A'	'B'	'C'	'D'	'E'	'F'	'G'				
20	20-1/4	10-3/4	6-3/8	4	45-5/8	8-1/2	10 [1]	4" Dia.	1/2	2.5	212
30	21-1/2	12	6	4	45-3/4	8-1/2	4-3/4	4" Dia.	1/2	3.2	254
40	24-3/4	15-1/4	7-5/8	5	47-1/8	9-1/8	4-3/4	5" Dia.	1/2	4.0	298
50	28	18-1/2	9-1/4	6	48-1/2	9-3/4	5-1/4	6" Dia.	1/2	4.7	346
60	31-1/4	21-3/4	10-7/8	6	48-1/2	9-3/4	5-1/4	6" Dia.	1/2	5.5	408
70	34-1/2	25	12-1/2	7	50-1/8	10-3/8	6-5/8	7" Dia.	3/4	6.2	450
80	37-3/4	28-1/4	14-1/8	7	50-1/8	10-3/8	6-5/8	7" Dia.	3/4	7.0	506
90	41	31-1/2	15-3/4	8	52	11	7-1/4	8" Dia.	3/4	7.7	550
100	44-1/4	34-3/4	17-3/8	8	52	11	7-1/4	8" Dia.	3/4	8.5	608

[1] CG20D only. Dimension 'G' includes allowance for 4" x 3" reducer furnished with boiler. See Figure 10.

[2] Refer to the National Fuel Gas Code for equivalent areas of circular and rectangular flue linings.

Maximum Allowable Working Pressure, Water - 50 PSI

Safety Relief Valve Pressure, Water - 30 PSI shipped from factory (std.)

The City of New York requires a Licensed Master Plumber supervise the installation of this product.

The Massachusetts Board of Plumbers and Gas Fitters has approved the CG-D™ Series Boiler. See the Massachusetts Board of Plumbers and Gas Fitters website, http://license.reg.state.ma.us/pubLic/pl_products/pb_pre_form.asp for the latest Approval Code or ask your local Sales Representative.

The Commonwealth of Massachusetts requires this product to be installed by a licensed Plumber or Gas fitter.

Table of Contents

I. Pre-Installation	3	VII. System Start-up and Checkout.....	18
II. Unpack Boiler.....	5	VIII. Operation	22
III. Water Piping and Trim.....	5	IX. Service and Maintenance	26
IV. Gas Piping	9	X. Troubleshooting.....	29
V. Venting.....	11	XI. Repair Parts	35
VI. Electrical.....	14		

I. Pre-Installation

WARNING

Carefully read all instructions before installing boiler. Failure to follow all instructions in proper order can cause personal injury or death.

- A. Inspect shipment** carefully for any signs of damage. All equipment is carefully manufactured, inspected and packed. Our responsibility ceases upon delivery of boiler to carrier in good condition. Any claim for damage or shortage in shipment must be filed immediately against carrier by consignee. No claims for variances or shortages will be allowed by Boiler Manufacturer, unless presented within sixty (60) days after receipt of equipment.
- B. Installation must conform** to the requirements of the authority having jurisdiction. In the absence of such requirements, installation must conform to *National Fuel Gas Code*, ANSI Z223.1/NFPA 54. Where required by the authority having jurisdiction, the installation must conform to the *Standard for Controls and Safety Devices for Automatically Fired Boilers*, ANSI/ASME CSD-1.
- C. Appliance is design certified for installation on combustible flooring.** The boiler must not be installed on carpeting.
- D. Provide clearance between boiler jacket and combustible material** in accordance with local fire ordinance. Refer to Figure 2 for minimum clearance from combustible material for closet installation.

For alcove or unconfined space installations height clearance maybe reduced to 27". Subject to boiler and system piping, left side clearance may be reduced to 1" if right side clearance is increased to 9".

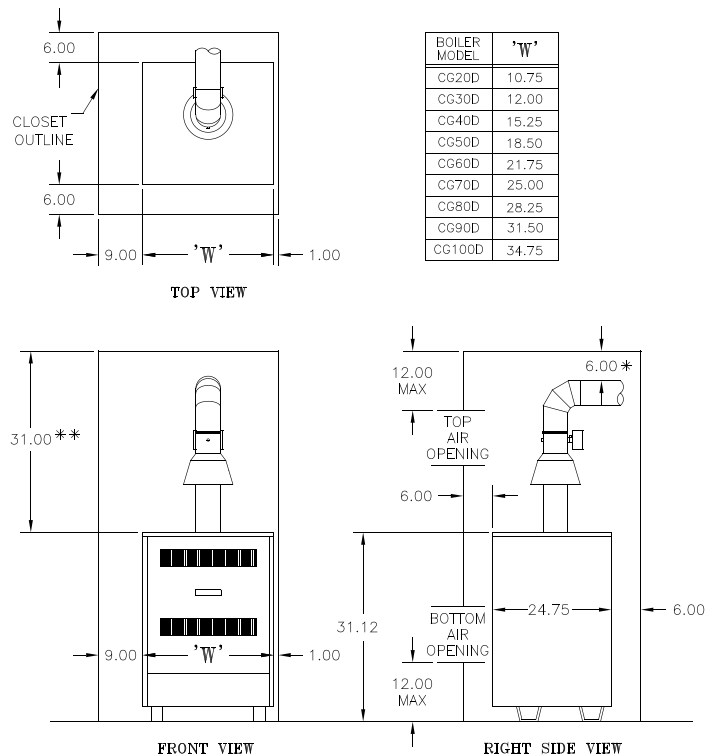

* MINIMUM RADIAL CLEARANCE AROUND DRAFT HOOD AND BREECHING.

** ADD HEIGHT REQUIRED TO MAINTAIN 6" CLEARANCE FROM ALL BREECHING COMPONENTS. VENT DAMPER MAY BE INSTALLED IN VERTICAL OR HORIZONTAL SECTION OF BREECHING WITHIN REACH OF CONTROL HARNESS.

Figure 2: Minimum Clearances to Combustible Construction for Closet Installation

E. Provide practical service clearances. A minimum of 24" from the left side and front jacket panels is recommended for servicing but may be reduced to minimums shown in Figure 2. Subject to boiler and system piping, left side clearance may be reduced to 1" if right side clearance is increased to 9".

F. Install on level floor. For basement installation provide concrete base if floor is not level or if water may be encountered on floor around boiler.

G. Protect gas ignition system components from water (dripping, spraying, rain, etc.) during boiler operation and service (circulator replacement, condensate trap, control replacement, etc.).

H. Provide combustion and ventilation air in accordance with the section "Air for Combustion and Ventilation" of the *National Fuel Gas Code*, ANSI Z223.1/NFPA 54, or applicable provisions of local building codes.

WARNING

Adequate combustion and ventilation air must be provided to assure proper combustion.

The following guideline is based on the *National Fuel Gas Code*, ANSI Z223.1/NFPA 54.

1. Determine volume of space (boiler room). Rooms communicating directly with space (through openings not furnished with doors) are considered part of space.
Volume [ft³] = Length [ft] x Width [ft] x Height [ft]
2. Determine Total Input of all appliances in space. Round result to nearest 1,000 Btu per hour (Btuh).
3. Determine type of space. Divide Volume by Total Input.
 - a. If result is greater than or equal to 50 ft³ per 1,000 Btuh, space is considered an *unconfined space*.
 - b. If result is less than 50 ft³ per 1,000 Btuh, space is considered a *confined space*.
4. Determine building type. A building of *unusually tight construction* has the following characteristics:
 - a. Walls and ceiling exposed to outside atmosphere have a continuous water vapor retarder with a rating of 1 perm or less with openings gasketed and sealed, and;
 - b. Weather-stripping has been added on openable windows and doors, and;
 - c. Caulking or sealants applied in joints around window and door frames, between sole plates and floors, between wall-ceiling joints, between wall panels, at plumbing and electrical penetrations, and at other openings.

5. For boiler located in an *unconfined space in a building of other than unusually tight construction*, adequate combustion and ventilation air is normally provided by fresh air infiltration through cracks around windows and doors.
6. For boiler located within *unconfined space in building of unusually tight construction* or within *confined space*, provide outdoor air through two permanent openings which communicate directly or by duct with the outdoors or spaces (crawl or attic) freely communicating with the outdoors. Locate one opening within 12 inches of top of space. Locate remaining opening within 12 inches of bottom of space. Minimum dimension of air opening is 3 inches. Size each opening per following:
 - a. Direct communication with outdoors. Minimum free area of 1 square inch per 4,000 Btu per hour input of all equipment in space.
 - b. Vertical ducts. Minimum free area of 1 square inch per 4,000 Btu per hour input of all equipment in space. Duct cross-sectional area shall be same as opening free area.
 - c. Horizontal ducts. Minimum free area of 1 square inch per 2,000 Btu per hour input of all equipment in space. Duct cross-sectional area shall be same as opening free area.

Alternate method for boiler located within confined space. Use indoor air if two permanent openings communicate directly with additional space(s) of sufficient volume such that combined volume of all spaces meet criteria for unconfined space. Size each opening for minimum free area of 1 square inch per 1,000 Btu per hour input of all equipment in spaces, but not less than 100 square inches.

7. Ventilation Duct Louvers and Grilles. Equip outside openings with louvers to prevent entrance of rain and snow, and screens to prevent entrance of insects and rodents. Louvers and grilles must be fixed in open position or interlocked with equipment to open automatically before burner operation. Screens must not be smaller than ¼ inch mesh.
Consider the blocking effect of louvers, grilles and screens when calculating the opening size to provide the required free area. If free area of louver or grille is not known, assume wood louvers have 20-25 percent free area and metal louvers and grilles have 60-75 percent free area.

I. Do not install boiler where gasoline or other flammable vapors or liquids, or sources of hydrocarbons (i.e. bleaches, cleaners, chemicals, sprays, paint removers, fabric softeners, etc.) are used or stored.

II. Unpack Boiler

CAUTION

Do not drop boiler. Do not bump boiler jacket against floor.

- A. Move boiler to approximate installed position.
- B. Remove all crate fasteners.
- C. Lift outside container and remove with all other inside protective spacers and bracing. Save two of the wooden slats from the container sleeve for use in Steps E and F.
- D. Remove all boiler hold-down fasteners.
- E. Tilt the boiler to one side and slide a wooden slat under the two raised feet.
- F. Tilt the boiler to the other side and slide another wooden slat under the two raised feet.
- G. Slide the boiler forward or backward off the skid using the two wooden slats as runners.
- H. Move boiler to its permanent location.

III. Water Piping and Trim

WARNING

Failure to properly pipe boiler may result in improper operation and damage to boiler or building.

- A. **Design and install boiler and system piping** to prevent oxygen contamination of boiler water.
Oxygen contamination sources are system leaks requiring addition of makeup water, fittings, and oxygen permeable materials in distribution system. Eliminate oxygen contamination by repairing system leaks, repairing fittings, and using nonpermeable materials in distribution system.
- B. **Install circulator** with flanges, gaskets and bolts provided. Five foot long circulator harness allows circulator to be mounted on supply or return. Connect harness to circulator and secure any excess conduit.
- C. **Install Safety Relief Valve.** See Figure 1. Safety Relief Valve must be installed with spindle in vertical position.
- E. **Space heating and domestic water heating** with the New Yorker Link SL™ indirect water heater. Install the New Yorker Link SL™ indirect water heater as a separate heating zone. Refer to the New Yorker Link SL™ Indirect Water Heater Installation, Operating and Service Instructions for additional information.
- F. **If boiler is used in connection with refrigeration systems**, boiler must be installed with chilled medium piped in parallel with the heating boiler using appropriate valves to prevent chilled medium from entering boiler. See Figure 4. Also consult Residential Hydronic Heating Installation and Design I=B=R Guide.
- G. **If boiler is connected to heating coils** located in air handling units where they may be exposed to refrigerated air, boiler piping must be equipped with flow control valves or other automatic means to prevent gravity circulation of boiler water during operation of cooling system.
- H. **Use a boiler bypass** if the boiler is to be operated in a system which has a large volume or excessive radiation where low boiler water temperatures may be encountered (i.e. converted gravity circulation system, etc.).

WARNING

Safety relief valve discharge piping must be piped near floor to eliminate potential of severe burns. Do not pipe in any area where freezing could occur. Do not install any shut-off valves.

- D. **Connect system supply and return piping** to boiler. Refer to Figure 3. Also consult Residential Hydronic Heating Installation and Design I=B=R Guide. Maintain minimum ½ inch clearance from hot water piping to combustible materials.
Remove circulator and install pipe tee between circulator and boiler return along with second tee in supply piping as shown in Figure 3. Bypass should be same size as the supply and return lines with valves located in bypass and supply outlet as illustrated in Figure 3 in order to regulate water flow to maintain higher boiler water temperatures.
Set by-pass and boiler supply valves to half throttle position to start. Operate boiler until system water temperature reaches normal operating range.

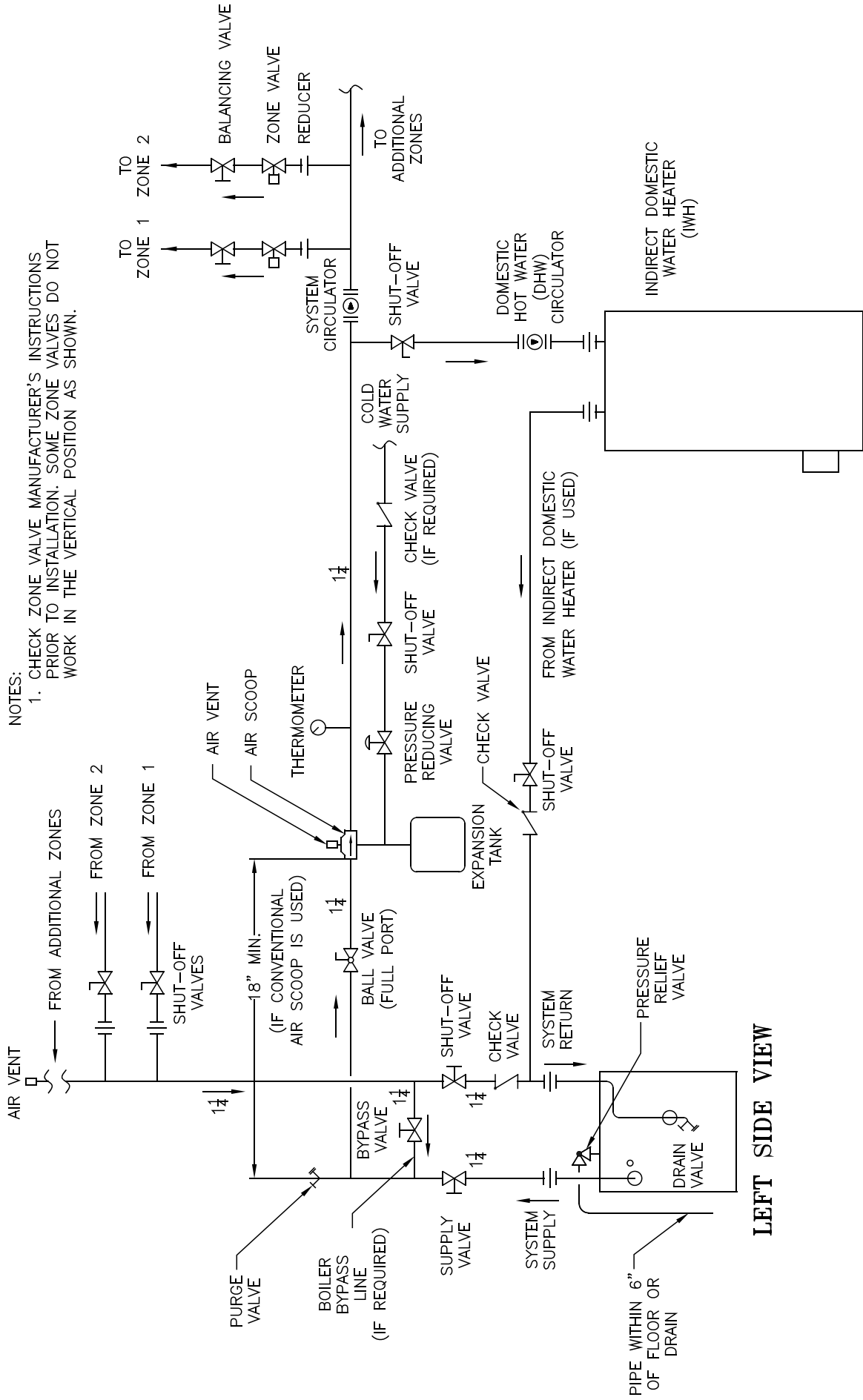
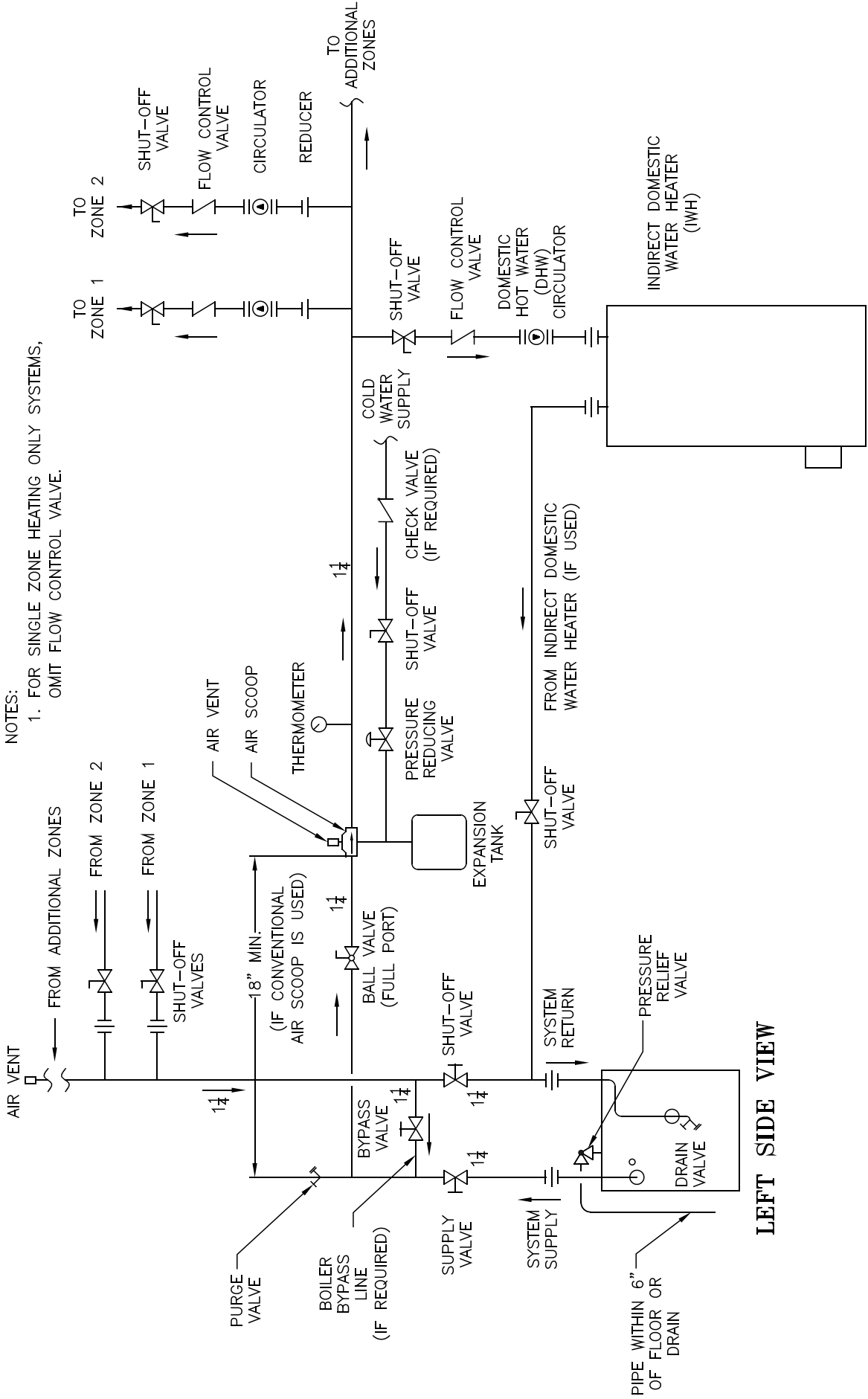

Figure 3: Recommended Water Piping for Zone Valve Zoned Heating Systems



NOTES:
 1. FOR SINGLE ZONE HEATING ONLY SYSTEMS,
 OMIT FLOW CONTROL VALVE.

Figure 4: Recommended Water Piping for Circulator Zoned Heating Systems

Adjust valves to provide 180° to 200°F supply water temperature. Opening the boiler supply valve will raise system temperature, while opening by-pass valve will lower system supply temperature.

I. If it is required to perform a long term pressure test of the hydronic system, the boiler should first be isolated to avoid a pressure loss due to the escape of air trapped in the boiler.

To perform a long term pressure test including the boiler, ALL trapped air must first be removed from the boiler.

A loss of pressure during such a test, with no visible water leakage, is an indication that the boiler contained trapped air.

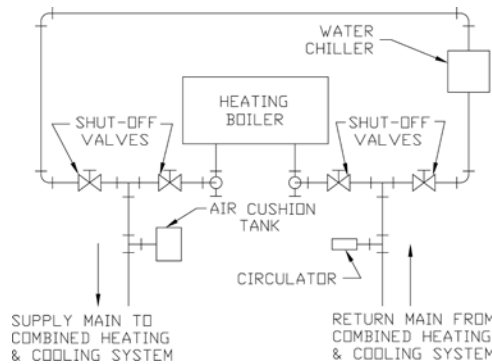

Figure 5: Recommended Piping for Combination Heating & Cooling (Refrigeration) Systems

J. Optional LWCO Installation

WARNING

DO NOT ATTEMPT to cut factory wires to install an aftermarket Low Water Cut Off (LWCO). Only use connections specifically identified for Low Water Cut Off.

In all cases, follow the Low Water Cut Off (LWCO) manufacturer's instructions.

1. A low water cutoff is required to protect a gas-fired hot water boiler when any connected heat distributor (radiation) is installed below the top of the hot water boiler (i.e. baseboard on the same floor level as the boiler). In addition, some jurisdictions require the use of a LWCO with a hot water boiler as a redundant safety control.

It is recommended that the LWCO control is installed above the boiler to provide the highest level of protection. However, where the LWCO control is approved by the LWCO control manufacturer for installation in a high boiler tapping of a water boiler, the use of the listed LWCO control is permitted when it is installed according to the LWCO manufacturer's instructions.

2. The recommended location for a LWCO on gas hot water boilers is above the boiler, in the supply piping. The minimum safe water level of a water boiler is at the uppermost top of the boiler; that is, it must be full of water to operate safely.
3. Typically, in residential applications, a probe type LWCO is used instead of a float type, due to their relative costs and the simplicity of piping for a probe LWCO.
4. Piping and fittings required to install LWCO **are field supplied.**
5. When constructing a piping tree to install LWCO select fittings (tees, elbows etc) and nipples to have the same size (NPT) as boiler supply connection. At minimum, 1-1/4" tee with 3/4" branch outlet is required to connect the probe LWCO to the supply piping. See Figure 6. **DO NOT REDUCE THE SIZE OF NEAR BOILER SUPPLY FITTINGS AND NIPPLES.**
6. Installation of manual shutoff valve located above the LWCO and the boiler is recommended to allow servicing. Thus LWCO probe can be removed for inspection without draining the heating system. An annual inspection of the probe is recommended.
7. The presence of water covering properly installed LWCO probe will cause the normally open contact of the LWCO to close, thus providing continuity of the 24 VAC service to the boiler gas valve. When water level drops below probe, LWCO contact opens up breaking 24V supply to gas valve and preventing the boiler to fire.
8. 2012 compliant CG-D Series gas hot water boilers have a "plug-in" provision in factory wiring that will accept optional 24VAC probe LWCO harness connector. The optional LWCO kit (P/N 104083-01) includes 24VAC probe LWCO, Harness and Instructions addressing piping, wiring and testing after installation.

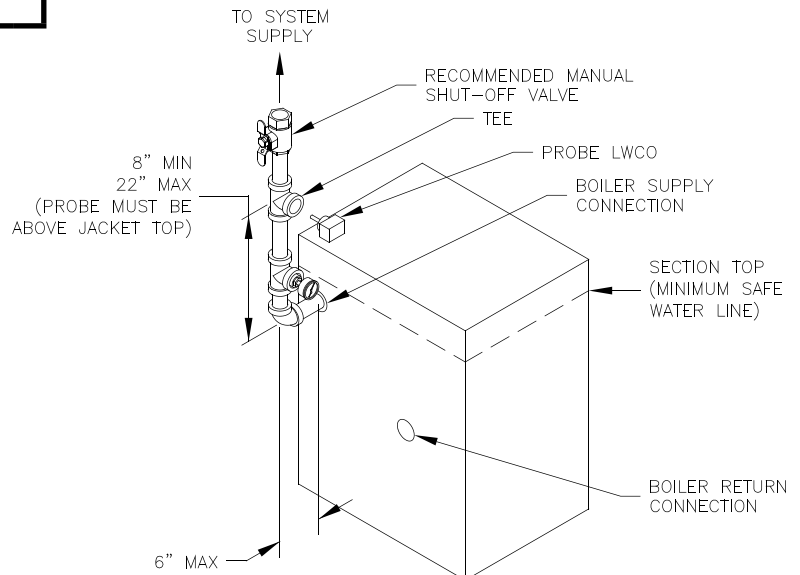

Figure 6: Recommended Probe LWCO Location

IV. Gas Piping

A. Size gas piping. Design system to provide adequate gas supply to boiler. Consider these factors:

1. Allowable pressure drop from point of delivery to boiler. Maximum allowable system pressure is $\frac{1}{2}$ psig. Actual point of delivery pressure may be less; contact gas supplier for additional information. Minimum gas valve inlet pressure is listed on rating label.
2. Maximum gas demand. Table 2 lists boiler input rate. Also consider existing and expected future gas utilization equipment (i.e. water heater, cooking equipment).
3. Length of piping and number of fittings. Refer to Table 3 for maximum capacity of Schedule 40 pipe. Table 4 lists equivalent pipe length for standard fittings.

Table 2: Rated Input

Boiler Model Number	Input Rate [cubic feet per hour]		Gas Connection Size
	Natural Gas	LP/Propane	
20	37.5	15.0	$\frac{1}{2}$
30	62.0	24.8	$\frac{1}{2}$
40	96.0	38.4	$\frac{1}{2}$
50	130.0	52.0	$\frac{1}{2}$
60	164.0	65.6	$\frac{1}{2}$
70	198.0	79.2	$\frac{3}{4}$
80	232.0	92.8	$\frac{3}{4}$
90	266.0	106.4	$\frac{3}{4}$
100	299.0	119.6	$\frac{3}{4}$

Table 3: Maximum Capacity of Schedule 40 Pipe in CFH for Natural Gas Pressures of 0.5 psig or Less

Length [Feet]	0.3 inch w.c. Pressure Drop				0.5 inch w.c. Pressure Drop			
	$\frac{1}{2}$	$\frac{3}{4}$	1	1 $\frac{1}{4}$	$\frac{1}{2}$	$\frac{3}{4}$	1	1 $\frac{1}{4}$
10	132	278	520	1,050	175	360	680	1,400
20	92	190	350	730	120	250	465	950
30	73	152	285	590	97	200	375	770
40	63	130	245	500	82	170	320	660
50	56	115	215	440	73	151	285	580
60	50	105	195	400	66	138	260	530
70	46	96	180	370	61	125	240	490
80	43	90	170	350	57	118	220	460
90	40	84	160	320	53	110	205	430
100	38	79	150	305	50	103	195	400

Table 4: Fitting Equivalent Lengths

Fitting	Nominal Pipe Size			
	$\frac{1}{2}$	$\frac{3}{4}$	1	1 $\frac{1}{4}$
45° Ell	0.7	1.0	1.2	1.6
90° Ell	1.6	2.1	2.6	3.5
Tee (As Elbow)	3.1	4.1	5.2	6.9

Table 5: Specific Gravity Correction Factors for Natural Gas

Specific Gravity	Correction Factor	Specific Gravity	Correction Factor
0.50	1.10	1.30	1.07
0.55	1.04	1.40	1.04
0.60	1.00	1.50	1.00
0.65	0.96	1.60	0.97
0.70	0.93	1.70	0.94
0.75	0.90		
0.80	0.87		

4. Specific gravity of gas. Corrections for the specific gravity of natural gas can be found in Table 5.

For materials or conditions other than those listed above, refer to *National Fuel Gas Code*, ANSI Z223.1/NFPA 54, or size system using standard engineering methods acceptable to authority having jurisdiction.

B. Connect boiler gas valve to gas supply system.

1. Use methods and materials in accordance with local plumbing codes and requirements of gas supplier. In absence of such requirements, follow *National Fuel Gas Code*, ANSI Z223.1 /NFPA 54.
2. Use thread (joint) compounds (pipe dope) resistant to action of liquefied petroleum gas.
3. Install sediment trap, ground-joint union and manual shut-off valve upstream of boiler gas control valve. See Figure 7.
4. All above ground gas piping upstream from manual shut-off valve must be electrically continuous and bonded to a grounding electrode. Do not use gas piping as grounding electrode. Refer to *National Electrical Code*, ANSI/NFPA 70.

C. Pressure test. The boiler and its gas connection must be leak tested before placing boiler in operation.

1. Protect boiler gas control valve. For all testing over $\frac{1}{2}$ psig, boiler and its individual shutoff valve must be disconnected from gas supply piping. For testing at $\frac{1}{2}$ psig or less, isolate boiler from gas supply piping by closing boiler's individual manual shutoff valve.
2. Locate leaks using approved combustible gas detector, soap and water, or similar nonflammable solution. Do not use matches, candles, open flames, or other ignition source.

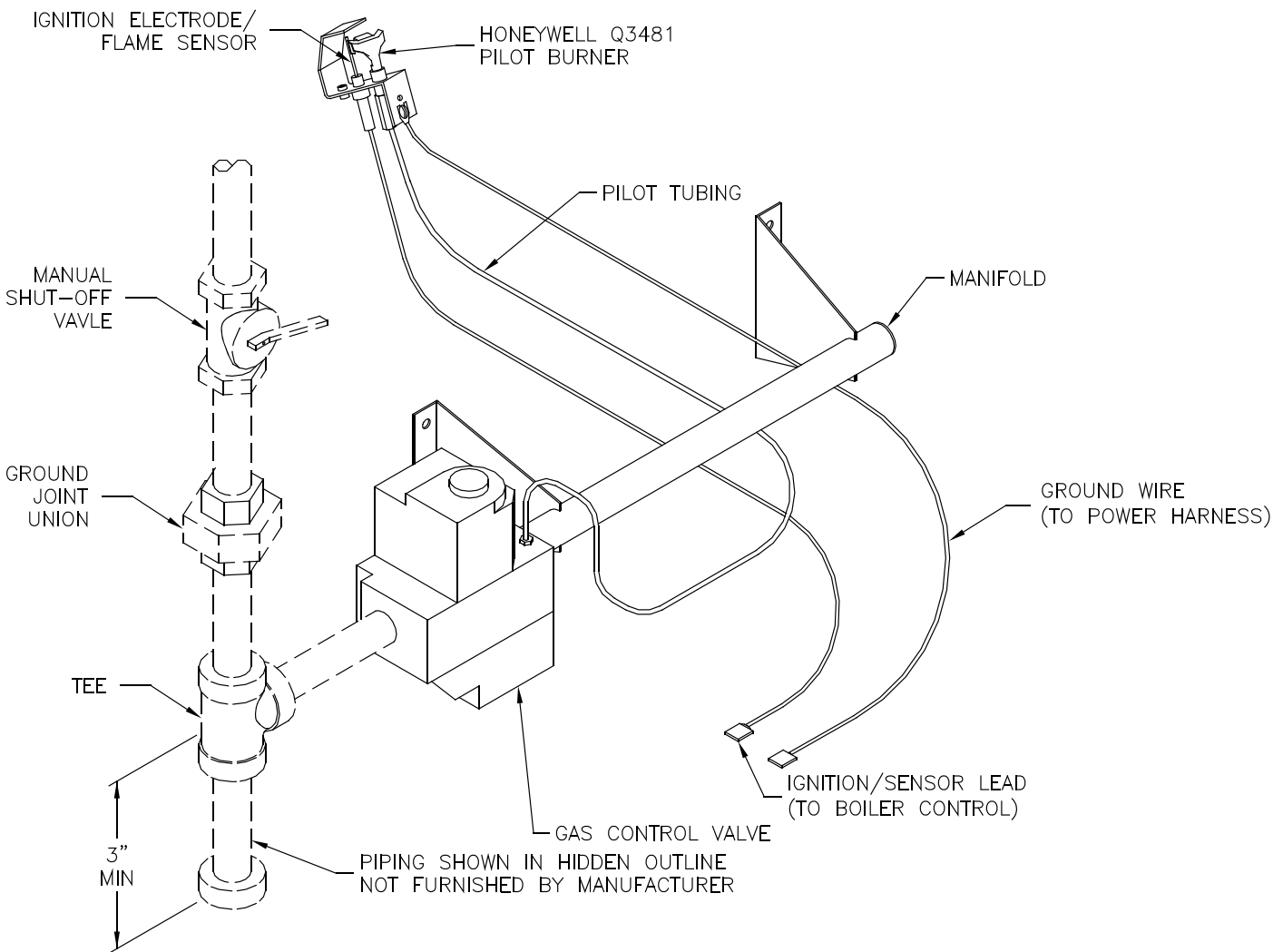

Figure 7: Pilot and Gas Piping

V. Venting

A. Install vent system in accordance with local building codes; or local authority having jurisdiction; or *National Fuel Gas Code*, ANSI Z223.1/NFPA 54. Install any of the following for this CG-D Series Category I, draft hood equipped appliance:

1. Type B or Type L gas vent. Install in accordance with listing and manufacturer's instructions.
2. Masonry or metal chimney. Build and install in accordance with local building codes; or local authority having jurisdiction; or *Standard for Chimneys, Fireplaces, Vents, and Solid Fuel Burning Appliances*, ANSI/NFPA 211.
Masonry chimney must be lined with approved clay flue lining or listed chimney lining system.
3. Single wall metal vent. Allowed by ANSI Z223.1/NFPA 54 under very restrictive conditions.
4. Do not use cellular core PVC (ASTM F891), cellular core CPVC, or Radel® (polyphenolsulfone).
5. Do not cover non-metallic vent pipe and fittings with thermal insulation. Note: Non-metallic vent cannot be used with this boiler.

B. Inspect chimney and remove any obstructions or restrictions. Clean chimney if previously used for solid or liquid fuel-burning appliances or fireplaces.

DANGER

Inspect existing chimney before installing boiler. Failure to clean or replace perforated pipe or tile lining will cause severe injury or death.

C. Install Draft Hood without modification on outlet of flue collector. See Figure 1. Secure with sheet metal screws.

WARNING

Do not alter boiler draft hood or place any obstruction or non-approved damper in the breeching or vent system. Flue gas spillage can occur. ETL certification will become void.

D. Install Blocked Vent Switch. The Blocked Vent Switch Assembly shipped taped to top of boiler includes power cord and switch attached to mounting bracket.

1. Untape Blocked Vent Switch Assembly from top of boiler. Uncoil power cord.
2. Position mounting bracket onto lower edge of Draft Hood skirt. Locate center tooth (with #10 sheet metal screw) on outside and other two teeth inside Draft Hood skirt. See Figure 8.

3. Slide mounting bracket tight against lower edge of Draft Hood skirt. Position #10 sheet metal screw above skirt's stiffening rib.
4. Secure bracket in position by tightening #10 sheet metal screw against outer surface of Draft Hood skirt.
5. Verify power cord, mounting bracket and Blocked Vent Switch are secure and located as shown in Figure 8.

WARNING

Failure to properly install and use this Blocked Vent Switch may result in property damage, personal injury or loss of life.

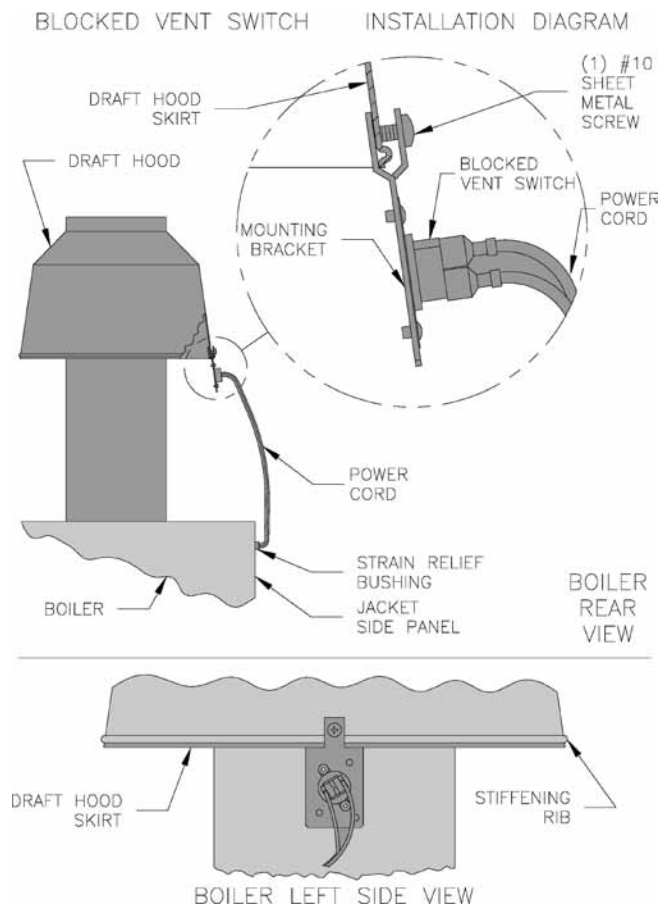

Figure 8: Blocked Vent Switch Installation

E. Install Vent Damper

OPEN THE VENT DAMPER CARTON and remove the Installation Instructions. READ THE INSTALLATION INSTRUCTIONS THOROUGHLY before proceeding.

The automatic gas control valve supplied on each CG-D Series boiler provides the redundancy referenced in the vent damper Installation Instructions.

CAUTION

Do not use one vent damper to control two heating appliances.

1. The vent damper must be the same size as the outlet of the Draft Hood supplied with the boiler (see Figure 1). Unpack the damper carefully - **DO NOT FORCE IT CLOSED!** Forcing the damper may damage the gear train and void the warranty.
2. Mount the vent damper assembly after the draft hood, as close to the draft hood as practicable without modification to the draft hood or vent damper. (Refer to Figure 9 and to instructions packed with the vent damper for specific instructions). This is a must for the wiring harness to fit and the damper position indicator to be visible to the users.

NOTICE

Provide adequate clearance for servicing.

WARNING

Provide 6" (15.2cm) minimum clearance between damper and combustible construction.

3. Plug the factory harness vent damper connector into damper motor polarized receptacle and secure the harness to the damper motor bracket with provided strain relief bushing.

DANGER

Inspect existing chimney before installing boiler. Failure to clean or replace perforated pipe or tile lining will cause severe injury or death.

F. Install Vent Connector

1. Model CG20D only - Install provided 4" x 3" vent reducer into vent damper outlet, then, install vent connector from reducer outlet to chimney.
2. All other sizes - Install vent connector from vent damper outlet to chimney.
3. Do not connect into same leg of chimney serving an open fireplace.
4. Inspect chimney for obstructions or restrictions and remove. Clean chimney if necessary.
5. Vent pipe to chimney must not be smaller than outlet on draft hood or damper. Although single wall vent pipe may be used, Type B is recommended. The venting system must be arranged so that only the boiler is served by the damper device.

Exception: *National Fuel Gas Code, ANSI Z223.1/ NFPA 54* allows vent downsizing when vent size determined by their Vent Sizing Tables is smaller than draft hood outlet/vent damper.

This code requires all of the following:

- (a) Total vent height (H) is at least 10 ft (3 m);
- (b) Vent not reduced more than one table size; and
- (c) Draft hood outlet/vent damper is greater than 4 in. (102 mm) in diameter (CG20D and CG30D cannot use smaller vent size).

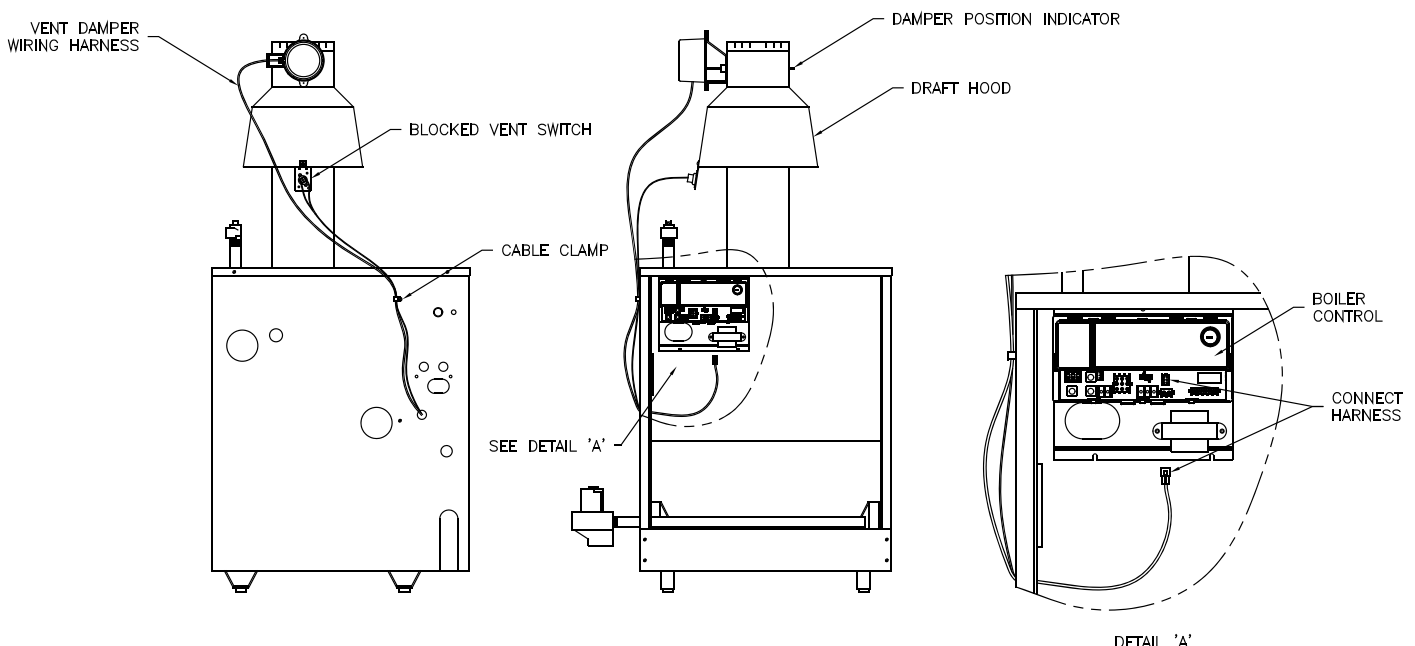

Figure 9: Vent Damper Installation

6. Where two or more appliances vent into a common vent, the area of the common vent should at least equal the area of the largest vent plus 50% of the area in the additional vents. Do not connect the vent of this appliance into any portion of mechanical draft system operating under positive pressure.
7. Vent pipe should have the greatest possible initial rise above the draft hood consistent with the head room available and the required clearance from adjacent combustible building structure. Vent Pipe should be installed above the bottom of chimney to prevent blockage.
8. Slope horizontal portions of vent pipe upwards not less than 1/4 in/ft from boiler to vent terminal.
9. Support horizontal portions of venting system to prevent sagging. Use pipe straps, brackets or hangers spaced 4 ft or less.
10. Vent pipe must be inserted into but not beyond inside wall of chimney liner. Seal tight between vent pipe and chimney.
11. Do not install non-listed (AGA, CGA, CSA, ETL or UL) vent damper or other obstruction in vent pipe.

WARNING

G. If an Existing Boiler is Removed:

When an existing boiler is removed from a common venting system, the common venting system is likely to be too large for proper venting of the appliances remaining connected to it.

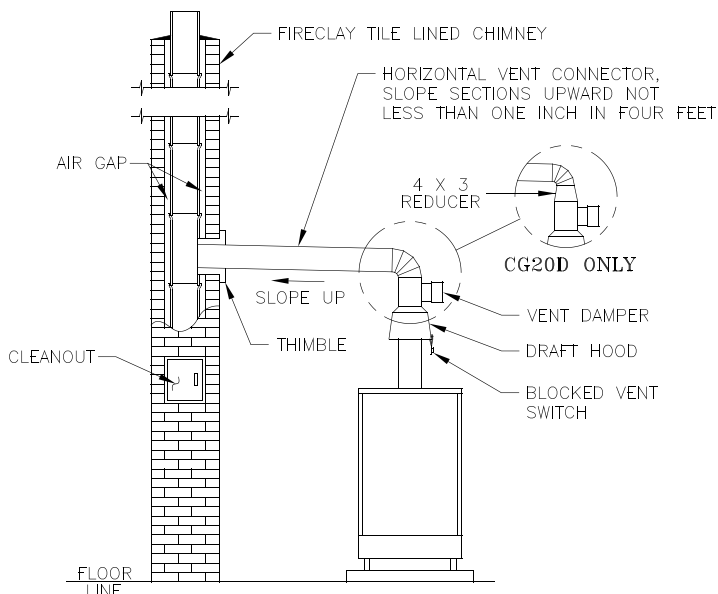

Figure 10: Typical Vent System Installation

At the time of removal of an existing boiler, the following steps shall be followed with each appliance remaining connected to the common venting system placed in operation, while the other appliances remaining connected to the common venting system are not in operation:

- a. Seal any unused openings in the common venting system.
- b. Visually inspect the venting system for proper size and horizontal pitch and determine there is no blockage or restriction, leakage, corrosion, and other deficiencies which could cause an unsafe condition.
- c. Insofar as is practical, close all building doors and windows and all doors between the space in which the appliances remaining connected to the common venting system are located and other spaces of the building. Turn on clothes dryers and any appliance not connected to the common venting system. Turn on any exhaust fans, such as range-hoods and bathroom exhausts, so they will operate at maximum speed. Do not operate a summer exhaust fan. Close fireplace dampers.
- d. Place in operation the appliance being inspected. Follow the Lighting (or Operating) Instructions. Adjust thermostat so appliance will operate continuously.
- e. Test for spillage at the draft hood relief opening after 5 minutes of main burner operation. Use the flame of a match or candle, or smoke from a cigarette, cigar or pipe.
- f. After it has been determined that each appliance remaining connected to the common venting system properly vents when tested as outlined above, return doors, windows, exhaust fans, fireplace dampers and any other gas-burning appliance to their previous condition of use.
- g. Any improper operation of the common venting system should be corrected so the installation conforms with the *National Fuel Gas Code*, ANSI Z223.1/NFPA 54. When resizing any portion of the common venting system, the common venting system should be resized to approach the minimum size as determined using the appropriate tables in Chapter 13 of the *National Fuel Gas Code*, ANSI Z223.1/NFPA 54.

VI. Electrical

- A. General.** Install wiring and ground boiler in accordance with requirements of authority having jurisdiction, or in absence of such requirements the *National Electrical Code*, ANSI/NFPA 70.
- B. Install thermostat.** Locate on inside wall approximately 4 feet above floor. Do not install on outside wall, near fireplace, or where influenced by drafts or restricted air flow, hot or cold water pipes, lighting fixtures, television, or sunlight. Allow free air movement by avoiding placement of furniture near thermostat.
- C. Wire thermostat.** Provide Class II circuit between thermostat and boiler. Set thermostat heat anticipator to 0.3 amps. See Figure 14.
- If system tends to overheat above thermostat's temperature setting, reduce heat anticipator setting by 0.1 or 0.2 amps. If system tends to shortcycle without reaching desired room temperature, increase heat anticipator setting by 0.1 or 0.2 amps.
- D. New Yorker Link SL™ indirect water heater (if used).** See Figures 11 and 12. Also refer to the New Yorker Link SL™ Indirect *Water Heater Installation, Operating and Service Instructions*.

- F. Wire boiler.** Boiler is rated for 120 VAC, 60 hertz, less than 15 amperes. A separate electrical circuit must be run from the main electrical service with an over-current device/disconnect in the circuit. A service switch is recommended and may be required by some local jurisdictions. Connect to black and white wires and green ground screw. See Figures 11 and 12.
- E. For installations using zone valves** provide separate transformer for zone valve wiring. Consult zone valve manufacturer for assistance. See Figure 13.

CAUTION

This boiler contains controls which may cause the boiler to shut down and not restart without service. If damage due to frozen pipes is a possibility, the heating system should not be left unattended in cold weather; or appropriate safeguards and alarms should be installed on the heating system to prevent damage if the boiler is inoperative.

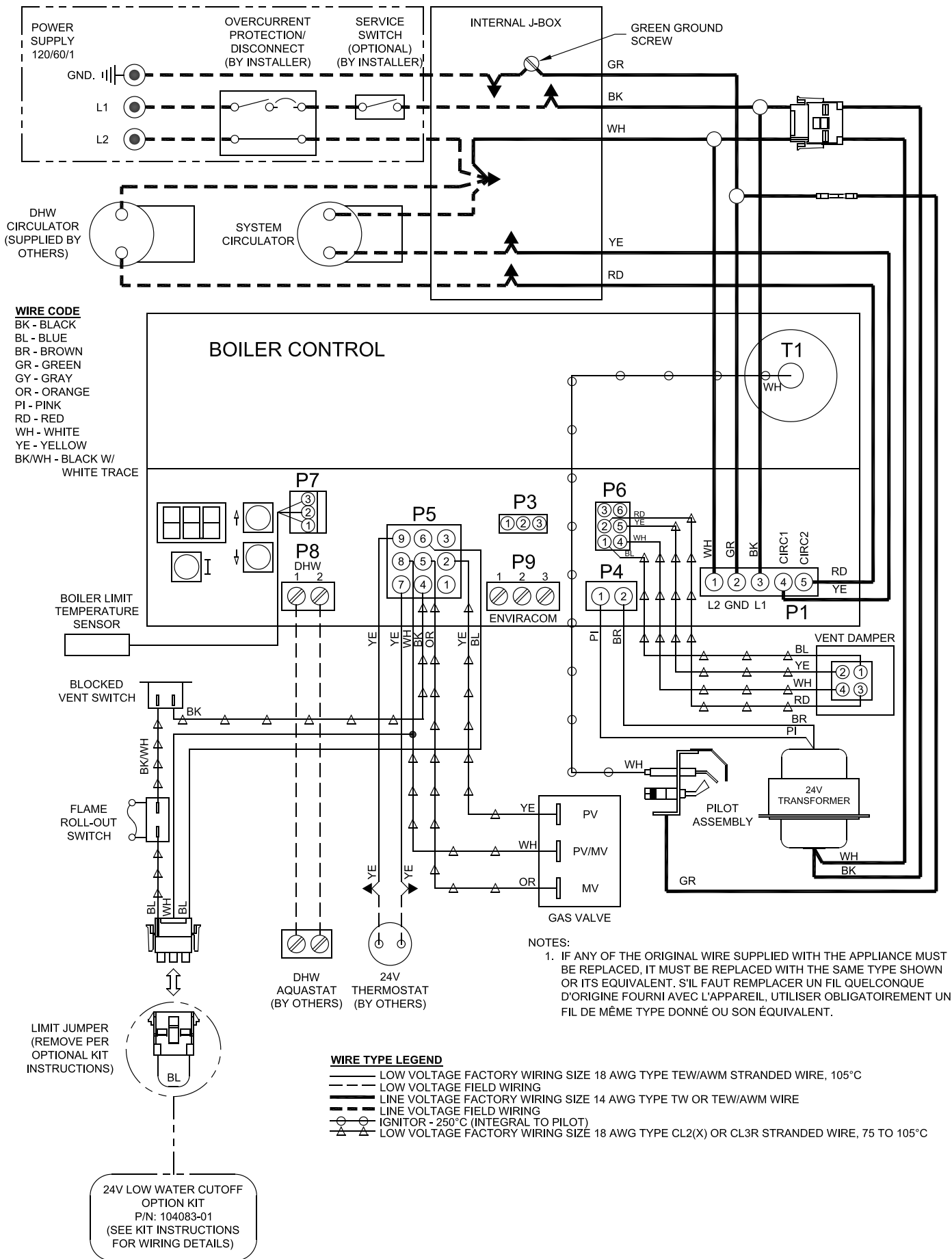

Figure 11: Wiring Schematic, Boiler Control

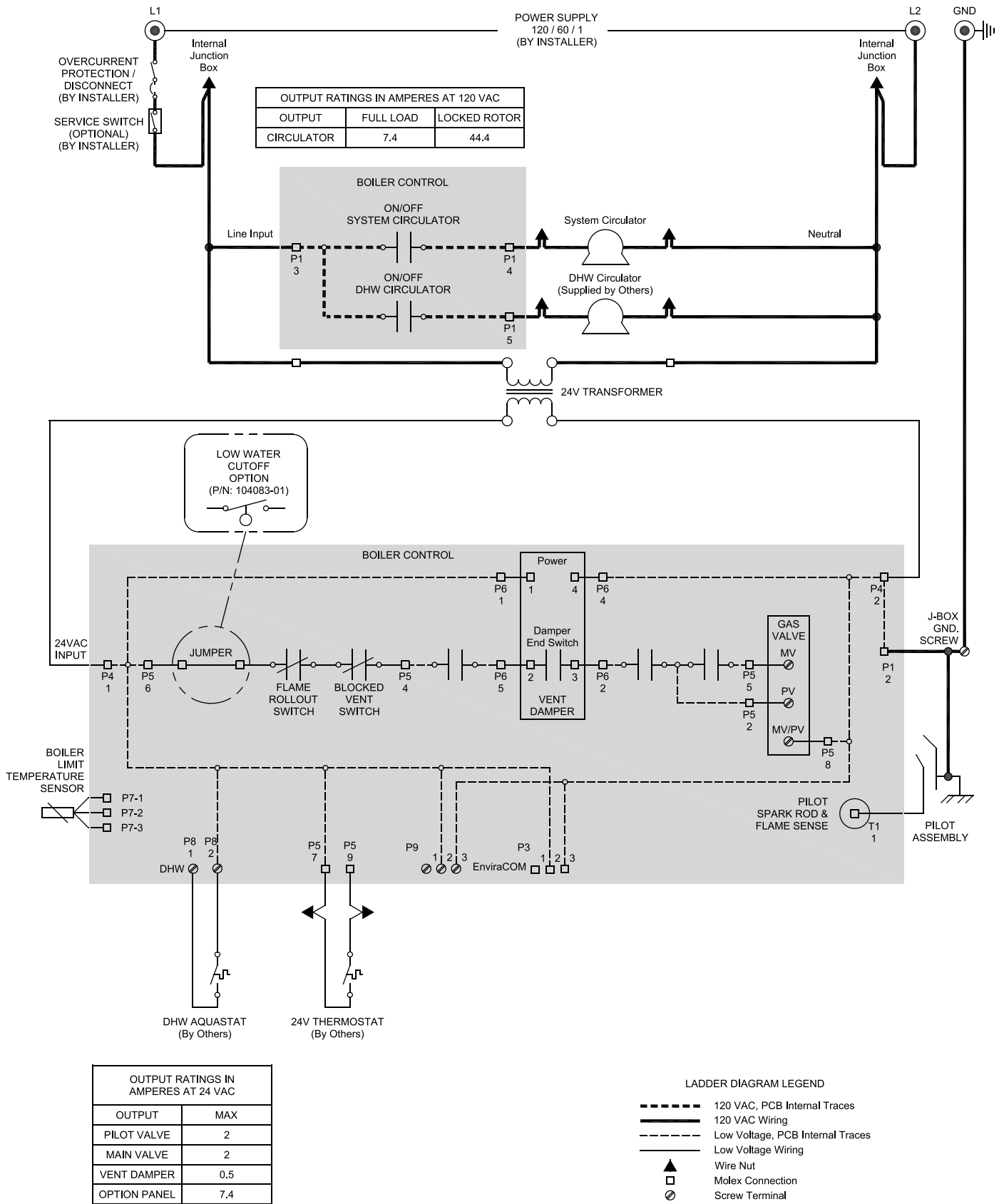

Figure 12: Wiring Schematic, Boiler Control

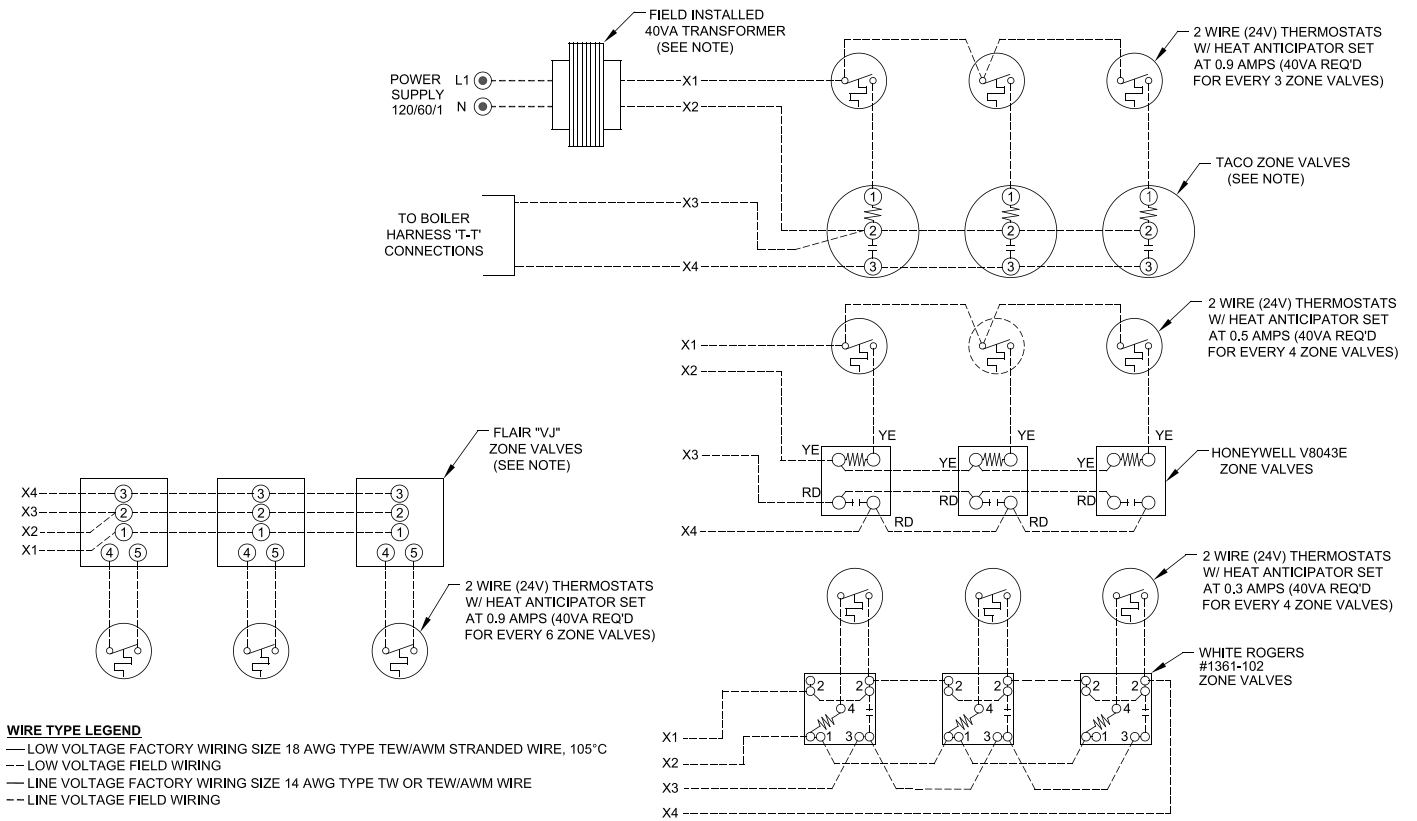

Figure 13: Wiring Schematic, Zone Valves

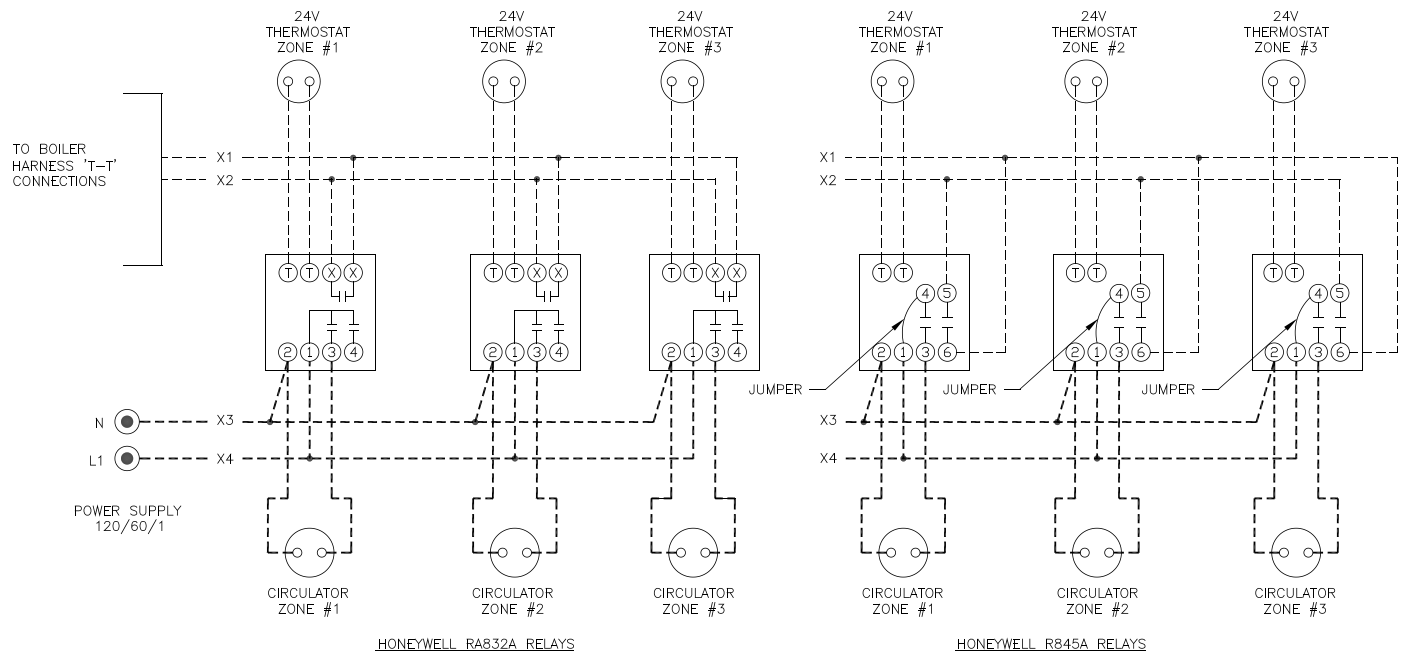

Figure 14: Wiring Schematic, Zone Circulators

VII. System Start-up and Checkout

A. Main Burner Check - Check main burners to see that they were not dislodged during shipment. Rear of burners should be in the vertical slots in the rear of burner tray and the front of the burners should be seated completely on the orifices.

B. Initial start -

1. **Fill entire heating system with water** and vent air from system. Use the following procedure on a System equipped with zone valves. (See Figure 3).
 - a. Close isolation valve in boiler supply piping.
 - b. Isolate all circuits by closing zone valves or balancing valves.
 - c. Attach a hose to hose bib located just below isolation valve in boiler supply piping. (Note - Terminate hose in five gallon bucket, at a suitable floor drain, or outdoor area).
 - d. Starting with one circuit, open zone valve.
 - e. Open hose bib.
 - f. Open fill valve (Make-up water line should be located directly above isolation valve in boiler supply piping).
 - g. Allow water to overflow from bucket until discharge from hose is bubble free for 30 seconds.
 - h. Open zone valve to the second zone to be purged, then close the first. Repeat this step until all zones have been purged, but always have one zone open. At completion, open all zone valves.
 - i. Close hose bib, continue filling the system until the pressure gauge reads 12 psi. Close fill valve. (Note - If make-up water line is equipped with pressure reducing valve, system will automatically fill to 12 psi. Leave globe valve open).
 - j. Open isolation valve in boiler supply piping.
 - k. Remove hose from hose bib.
2. Turn ROOM THERMOSTAT to lowest setting.
3. Be sure that gas to pilot and main burners has been off for at least five minutes and vent damper has been in the open position.

4. Turn "OFF" the electric switch serving boiler.
5. Open valve on main gas line at meter.
6. **PURGE AIR FROM GAS PIPING. Adequate ventilation must be provided and no smoking or open flame permitted.**
7. Turn "ON" electric switch serving boiler.
8. Open Manual Shut-off Valve upstream of Combination Gas Valve.
9. Loosen or remove Inlet Pressure Tap Plug in Combination Gas Valve and when purging is complete, tighten or replace plug. (See Figure 15).
10. Check pipe and fittings from meter to Combination Gas Valve using soap solution or other approved methods.

CAUTION

11. Test gas piping and connections between Combination Gas Valve and manifold, orifices, and pilot piping for leaks after boiler is operating. Use soap solution or other approved method.

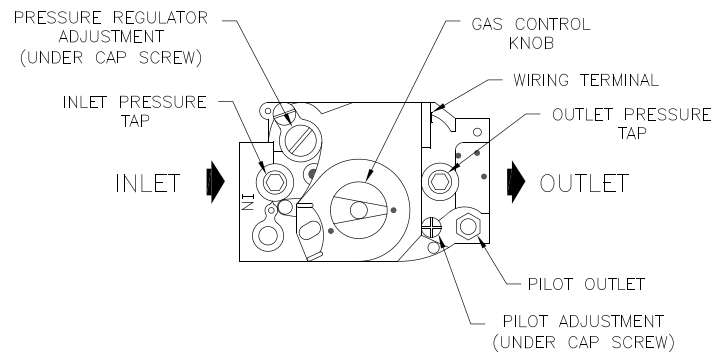



Figure 15: Top View of Honeywell Gas Valves

FOR YOUR SAFETY READ BEFORE OPERATING

WARNING: If you do not follow these instructions exactly, a fire or explosion may result causing property damage, personal injury, or loss of life.

- A. This appliance is equipped with an ignition device which automatically lights the pilot. Do not try to light the pilot by hand.
- B. BEFORE OPERATING smell all around the appliance area for gas. Be sure to smell next to the floor because some gas is heavier than air and will settle on the floor.
- WHAT TO DO IF YOU SMELL GAS**
- ▶ Do not try to light any appliance.
 - ▶ Do not touch any electric switch; do not use any phone in your building.
 - ▶ Immediately call your gas supplier from a neighbor's phone. Follow the gas supplier's instructions.
- ▶ If you cannot reach your gas supplier, call the fire department.
- C. Use only your hand to push in or turn the gas control knob. Never use tools. If the knob will not push in or turn by hand, don't try to repair it, call a qualified service technician. Force or attempted repair may result in a fire or explosion.
- D. Do not use this appliance if any part has been under water. Immediately call a qualified service technician to inspect the appliance and to replace any part of the control system and any gas control which has been under water.

OPERATING INSTRUCTIONS

1. STOP! Read the safety information above on this label.
2. Set the thermostat to lowest setting.
3. Turn off all electric power to the appliance.
4. This appliance is equipped with an ignition device which automatically lights the pilot. Do not try to light the pilot by hand.
5. Locate the gas control valve at the end of the gas supply pipe going into the boiler. The gas control knob is the brown or blue plastic knob located on top of the gas control valve.
6. Rotate gas control knob clockwise  from "ON" position to "OFF". Make sure knob rests against stop.
7. Wait five (5) minutes to clear out any gas. Then smell for gas, including near the floor. If you smell gas, STOP! Follow "B" in the safety information above on this label. If you do not smell gas, go to the next step.
8. Rotate gas control knob counterclockwise  from "OFF" to "ON". Make sure knob rest against stop. Do not force.
9. Turn on all electric power to the appliance.
10. Set thermostat to desired setting.
11. If the appliance will not operate, follow the instructions "TO TURN OFF GAS TO APPLIANCE" and call your service technician or gas supplier.

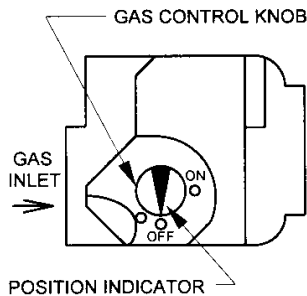

TO TURN OFF GAS TO APPLIANCE

1. Set the thermostat to lowest setting.
2. Turn off all electric power to the appliance if service is to be performed.
3. Rotate gas control knob clockwise  from "ON" position to "OFF". Make sure knob rests against stop.

Figure 16: Operating Instructions

C. Check Gas Input to Boiler

NOTICE

CG-D Series boilers built for installation at altitudes greater than 2,000 feet above sea level have been specially orificed to reduce gas input rate 4 percent per 1,000 feet above sea level per the National Fuel Gas Code, ANSI Z223.1/NFPA 54. High altitude boiler models are identifiable by the second digit in the part number suffix on the rating label:

CG_0D_I- _2: up to 2000 ft. elevation
CG_0D_I- _5: 2000 to 5000 ft. elevation

1. Input Rate and Maximum Inlet Pressure shown on Rating Label must not be exceeded. Inlet pressure must not be lower than minimum inlet pressure shown on Rating Label.
2. All Rate checks and all adjustments are to be made while boiler is firing - all other appliances connected to the same meter as the boiler must be off.
3. With boiler off, water Manometer or water column gauge should be connected to a shut-off valve installed in the 1/8" outlet pressure tap in the gas valve (See Figure 15). By installing gas valve upstream of manometer, gas pressure can be introduced gradually - without shut-off valve; surge of pressure when boiler is turned on, could blow liquid out of manometer. Replace plug in gas valve when rate check is finished.
4. LP Gas Input:
Adjust Regulator on Gas Valve so that manifold pressure is 10 inches water column. Turning Regulator Adjusting Screw Clockwise increases pressure. Counterclockwise rotation decreases pressure.
5. Natural Gas Input
 - a. Approx. Input - Adjust regulator on Gas Valve so that manifold pressure is three and a half (3½) inches water column (three inches water column for high altitude). Turning Regulator Adjusting Screw Clockwise increases pressure, Counterclockwise rotation decreases pressure. If more accurate check on input is necessary see (b) .
For minor input changes readjust Regulator Gas Valve to increase or decrease manifold pressure to obtain corresponding increase manifold pressure more than 0.3" of water to obtain rated input, remove orifices and drill one size larger. Reinstall and recheck input rate.
 - b. Additional Check on Input - Since input is a function of heating value, specific gravity, and volume of gas flow contact your utility for the

first two items in order to utilize the formula below. The gas meter should then be clocked for three (3) minutes with stop watch and substituting the appropriate values in the formula below, determine what the gas flow should be in this 3 minute period to give the input shown on the Rating Label:

$$\text{Gas Input cu. ft. per 3 min.} = \frac{\text{Btuh Input}}{\text{Heating Value of Gas (Btu / cu. ft.)} \times \text{Multiplier from Table 5}}$$

- D. Check Main Burner Flame.** See Figure 17 or 18. Flame should have a clearly defined inner cone with no yellow tipping. Orange-yellow streaks caused by dust should not be confused with true yellow tipping.

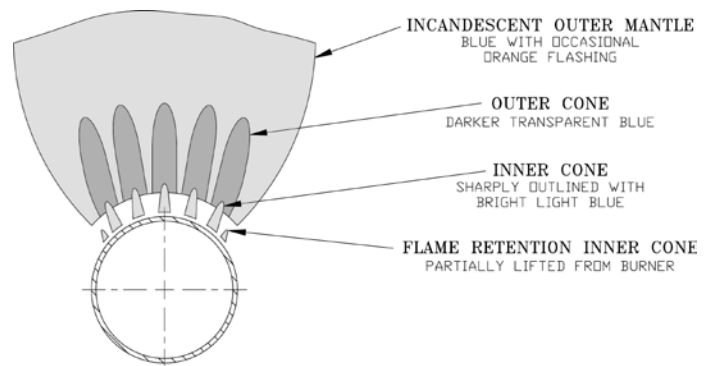

Figure 17: 40mm Main Burner Flame

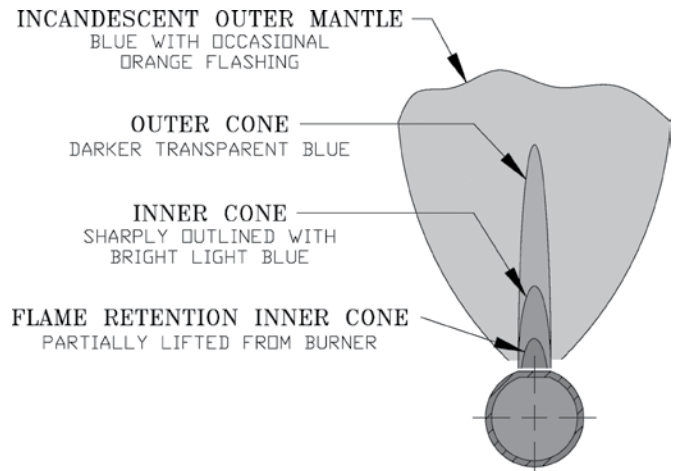

Figure 18: 1 Inch Main Burner Flame

CAUTION

Avoid operating this boiler in an environment where saw dust, loose insulation fibers, dry wall dust, etc. are present. If boiler is operated under these conditions, the burner interior and ports must be cleaned and inspected daily to insure proper operation.

E. Check Pilot Burner Flame.

1. See Figure 19. The pilot burner should be lit only if thermostat is calling for heat. The pilot burner produces three (3) flames. The center flame should be steady, medium hard blue enveloping 3/8 to 1/2 inch of thermocouple.

F. Check Ignition System Safety Shut-off Device.

Remove 3-wire plug from gas valve.

If burners do not shut down determine cause of malfunction. Replace necessary items and check operation.

G. Check Vent Damper Operation. Vent Damper must be in open position when main burners are ignited.

H. Check High Limit Control.

Jumper Thermostat connections in boiler wiring harness. Allow burners to operate until shutdown by limit. REMOVE JUMPER.

I. Check Thermostat Operation. Raise and lower temperature setting to start and stop boiler operation. Adjust thermostat to normal setting.

J. Combustion Chamber Burn-off

1. The mineral wool combustion chamber panels may contain a cornstarch based binder that must be burned out at installation to prevent odors during subsequent boiler operation.
2. Ventilate the boiler room, set the high limit to its maximum setting, set the thermostat to call for heat.

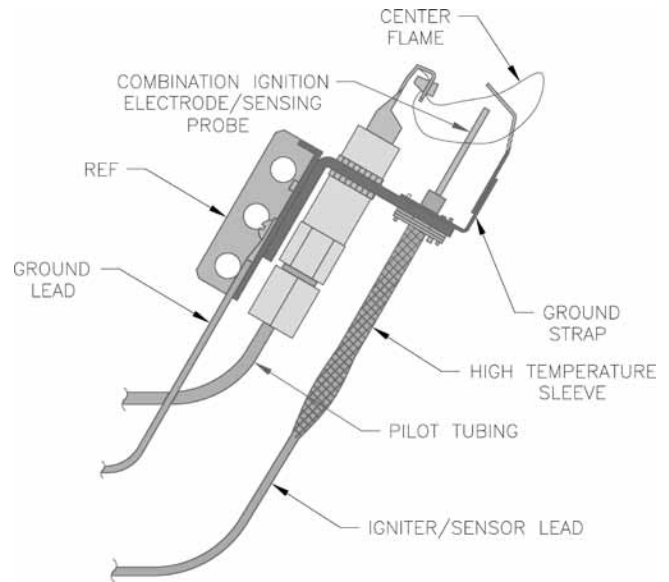

Figure 19: Pilot Burner Flame

Allow the boiler to fire for at least an hour or until the odor from the cornstarch has dissipated.

3. Return the high limit and thermostat to their desired settings.

K. Review User's Information Manual and system operation with owner or operator.

L. Post instructions near boiler for reference by owner and service personnel.

VIII. Operation

A. BOILER SEQUENCE OF OPERATION

NORMAL OPERATION

1. The CG-D Series Boilers are equipped with a Boiler Control (control). This control replaces the traditional separate ignition control, high limit switch and circulator relay and adds energy saving thermal purge features. Energy is saved by starting the circulator and delaying the burner start when there is residual heat available in the boiler.
2. The boiler's sequence of operation is shown in Table 4.
3. When the thermostat calls for heat the control starts the system circulator and the thermal purge (circulator Pre-purge time) begins. If the time is completed or boiler temperature is less than the Start Temperature (140°F default) the start sequence continues by energizing the vent damper. Once the vent damper is fully open the ignition sequence is started allowing gas flow and ignition of the burners.
4. If the thermostat is not satisfied and the operating setpoint is reached the system circulator will continue to operate and the burners will stop. When the boiler water temperature drops below the setpoint less the differential setting the burners will restart.
5. After the thermostat is satisfied the burners and circulator are stopped and vent damper is closed.
6. When an indirect water heater aquastat call for heat is wired to the DHW input, the control starts the Domestic Hot Water circulator and, if the boiler temperature is less than the operating setpoint less differential, the vent damper is energized without delay. Once the vent damper is fully open, the ignition sequence is started allowing gas flow and ignition of the burners.

B. BOILER FAULT

In the event the boiler fails to start, the control provides status information to help determine the cause of the problem. Table 5 provides a list of boiler status codes that are reported. Refer to the Troubleshooting Section for more information.

C. USING DISPLAY

The control is located inside the boiler front door. (Figure 20).

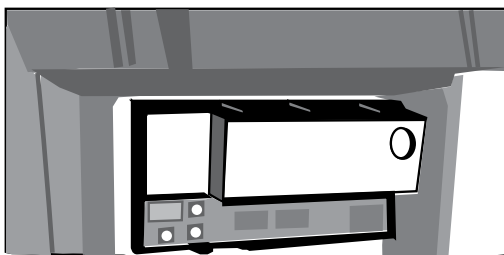

Figure 20: Boiler Control

Table 4: Sequence of Operation

Status Codes displayed in 5LR Mode		
Status	5LR	Description
Standby (Burner off Circulator off)	1	No call for heat detected
Circulator Pre-purge (burner off circulator on)	1	Either condition is true: a. Call for heat detected and boiler temperature higher than operating setpoint. b. Call for heat detected and boiler temperature higher than Start Temperature (140°F default) and Circulator Pre-purge Time has not expired.
Self Test	17	Control internal checking
Drive Damper Open	18	The damper is energized. The control is waiting for the damper switch to close. If the damper end switch doesn't close within 60 seconds, the control goes to 5LR 20
Pre-purge	4	Damper is open for a 2 second delay
Spark	6	The pilot fuel valve is open and sparking is started.
Flame Proving	7	The main fuel valve is open and flame is being proven.
Running	8	The burner runs until the call for heat is satisfied or the operating setpoint is reached.

Table 5: Sequence Fault

Status Codes displayed in 5LR Mode		
Status	5LR	Description
Retry / Recycle Delay	10	If the burner fails to light off (no flame signal), it waits 5 minutes and retries or if the control loses flame signal during running, it will wait 10 seconds and then recycle.
Soft Lockout	13	System is shutdown and will restart following a one hour enforced delay.
Hard Lockout	14	System is locked out. A manual or power reset is required to be able to light off again.
Limit Open	15	There is a call for heat from the thermostat, but a Safety Limit is open.
Flame Present Out of Sequence	16	Flame signal is still present when expected to be 0 (no flame).
Damper Failed to Open	20	The damper is still energized and the damper end switch has not closed.

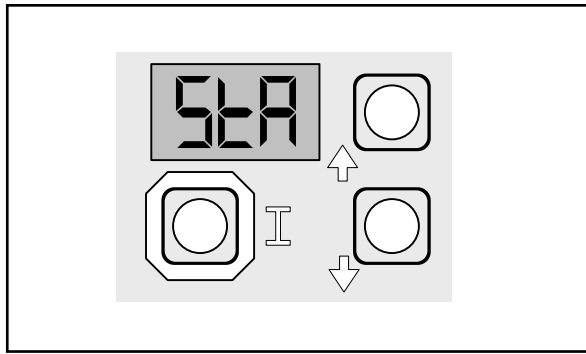

Figure 21: Boiler Display

The control display, along with Up \uparrow , Down \downarrow , and “T” keys may be used to view boiler operating status (Figure 21).

D. VIEWING THE OPERATING MODE OPTIONS

In operating mode the user may view (but not change) boiler operating status, settings and troubleshooting information.

To view control display information:

1. Press and release the “T” key on the control to change from one parameter to the next. Each setting will alternately flash between the relevant display code and its corresponding value.

Operating Mode Options	
5tA	Status
bE	Boiler Temperature
SP	Operating Setpoint (Outdoor Reset)
HL	High Limit Setting
HdF	High Limit Differential
tE	Heat Request Status
dh	DHW Heat Request Status
FLA	Flame Current
rUn	Run Time Hours
CLC	Boiler Cycles
Err	Error (see Error Numbers)

The 5tA (status) display code has the below listed values. This list is also available on the control cover.

Status Code Displayed in 5tA Mode	
1	Standby
4	Prepurge
6	Spark
7	Flame Proving
8	Running
10	Retry/Recycle Delay
13	Soft Lockout
14	Hard Lockout
15	Waiting for Limit to Close
16	Flame Present Out of Sequence
17	Self Test
18	Waiting for Damper to Open
20	Damper Failure to Open

For example, when the “T” key is pressed on the control until “bE” is displayed, it will then flash a three digit number (such as “180”) followed by either “F” (or “C”). This indicates that the boiler water temperature is 180°F. Other operating parameters display the information in a similar fashion.

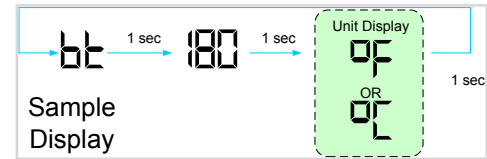

Please note that in operating mode to hold the display on the value the user can press and hold either the Up \uparrow or Down \downarrow keys and the value will be continuously shown. This may be helpful in watching a value “live”.

E. CHANGING THE ADJUSTABLE PARAMETERS

To adjust parameters such as High Limit Setpoint and High Limit Differential:

1. Access the adjustment mode by pressing and holding the Up \uparrow , Down \downarrow , and “T” keys simultaneously for three (3) seconds. This procedure is intended to discourage unauthorized changes or accidental changes to limit settings.
2. Press the “T” key to display available Adjustment Mode options. Select an option.

Adjustment Mode Options		
HL_	140-220°F	Adjust High Limit Setting
dF_	10-30°F	Adjust High Limit Differential
Or_	0-10 minutes	Circulator Overrun Time
PP_	2-20 minutes	Circulator Pre-purge Time
St_	140-180°F	Start Temperature
Pt_	On or off	Priority time
dh_	dh or tE2	DH Terminal Function
rSt		Reset Lockout
F-C	F or C	Select degrees F or C Mode
bAc		Back to Operating Mode

3. Press the Up \uparrow and Down \downarrow keys to adjust the displayed item to the desired value.
4. To return to the normal operating mode from the Adjustment Mode, when the “bAc” option is displayed, press either the Up \uparrow or Down \downarrow key. If no keys are pressed, after five (5) minutes the control will automatically return to the Operating Mode.

F. MORE INFORMATION ABOUT ADJUSTABLE PARAMETERS

1. High Limit (HL_)

The control is factory programmed with a High Limit Setpoint of 180°F. The burner turns “off” when the boiler water temperature (bE) is above this value. The High Limit setpoint is adjustable between 140° and 220°F. The Operating Setpoint (SP) will equal the High Limit Setpoint.

2. Differential (dF_{-})

The control is factory programmed with a Differential of 15°F. The Differential is the number of degrees the boiler temperature must decrease below the Operating Setpoint before the boiler can restart. The differential is adjustable between 10° through 30°F.

3. Circulator Overrun Time ($\overline{O}r_{-}$)

The control is factory programmed with a Circulator Overrun Time of 0 minutes. Circulator Overrun Time (also called “circulator off delay” or “circulator post purge”) continues circulator operation after a call for heat has ended, sending excess heat from the boiler into the system. Ensure system piping and zone panel settings allow water flow to the priority zone after the call for heat ends. The Circulator Overrun Time is adjustable between 0 through 10 minutes.

4. Circulator Pre-purge Time (PP_{-})

When the boiler is warm (boiler water temperature higher than 140°F (adjustable using Start Temperature parameter)) and there is a thermostat call for heat, the system circulator is started and boiler firing is delayed Circulator Pre-purge minutes. If the temperature drops below 140°F or there is a DHW call for heat the boiler is started without delay. Additionally, the boiler is started without delay if the thermostat call for heat is initiated when the boiler water temperature is less than 140°F. This feature helps save energy by satisfying home heating needs with residual boiler heat rather than cycling the boiler. The Circulator Pre-purge time has a factory setting of 2 minutes and is field adjustable between 2 and 20 minutes. Refer to Table 6.

5. Start Temperature (5E_{-})

Amount of “Heat available” is calculated by taking the difference between measured boiler water temperature and the Start Temperature setting. Useful “Heat Available” is dependent on the type of heating emitter installed in the home. Heat emitters require a certain minimum temperature to operate effectively. Our default settings reflect cast iron radiators. Fan Coils may require a start temperature setting of 180°F or 160°F before providing heat to the home. The Start Temperature has a factory setting of 140°F and is field adjustable between 140°F and 180°F.

6. Priority Time ($P\text{E}_{-}$)

When the Priority Time parameter is set to “on” and Domestic Hot Water (DHW) call for heat is “on” the DHW demand will take “Priority” over home heating demand. During Priority Time the system circulator will be forced “off”. Priority Time ends and the system circulator is released to service home heating demand when Domestic Hot Water call for

heat is over. When Priority Time parameter is set to “Off” the DHW call for heat does not force “off” the system circulator. The Priority Time has a factory setting of “On” and is field adjustable between “On” and “Off” Refer to Table 7.

7. Domestic Hot Water (DHW) Terminal Function (dh_{-})

The control allows configuration of the DHW Circulator output functionality to help the CG-D Series integrate into each installation more effectively. The DHW Circulator output can be connected to a domestic hot water circulator or a second heating zone circulator. These applications are selected as follows:

a. When dh_{-} is set equal to Domestic Hot Water Demand (dh)

When there is an Indirect Water Heater (IWH) the control provides “DHW” input terminals for the IWH Aquastat and “DHW Circulator” output terminals for the DHW Circulator.

When there is a DHW call for heat, the System Circulator is “forced off”, the DHW Circulator terminal is energized and the circulator pre-purge time delay control logic is bypassed to allow the boiler to fire without delay. When DHW demand ends the System Circulator “force off” is removed, the circulator can respond normally, and the DHW Circulator is de-energized. The DHW call for heat is detected by a voltage on to the “DHW” terminal. When the Priority Time parameter is set to “OFF” the System Circulator is not forced off for a DHW call for heat. Refer to Table 7.

b. When dh_{-} is set equal to Second Heating Zone (EEZ)

When there is no IWH the “DHW Circulator” output may be configured to control a second heating zone. This is particularly helpful when the home uses only two heating zones. The control replaces the need for a two circulator zone panel. When DHW Terminal Function (dh_{-}) is set to “ EEZ ” the control’s two circulator outputs are used to control two independent heating zones. Refer to Table 8. A “TT” input causes a call for heat and energizes the “System Circulator” output to service heating zone 1 and a second zone's thermostat wired to the “DHW” input causes a call for heat and energizes heating zone 2 circulator wired to the “DHW Circulator” output.

When there is a Second Heating Zone (call for heat) the boiler is started and the DHW Circulator terminal is energized. When Second Heating Zone terminal is de-energized the call for heat is ended and the DHW Circulator is de-energized. A Second Heating Zone is detected by sensing a voltage on the DHW terminal.

Table 7: DHW Terminal Function (*dh_*)
Selection = Domestic Hot Water Demand,
(Parameter *dh_* = *dh*)

Call for Heat		Priority Time (<i>Pt_</i>)	Circulator Status	
T-T Input	DHW Input		System Circulator Output	DHW Circulator Output
on	off	<i>On</i>	on	off
on	on	<i>On</i>	off	on
off	on	<i>On</i>	off	on
on	off	<i>OFF</i>	on	off
on	on	<i>OFF</i>	on	on
off	on	<i>OFF</i>	off	on

Table 8: DHW Terminal Function (*dh_*)
Selection = Second Heating Zone,
(Parameter *dh_* = *tt2*)

Call for Heat		Circulator Status	
T-T Input	DHW Input	System Circulator Output (Zone 1)	DHW Circulator Output (Zone 2)
off	off	off	off
on	off	on	off
on	on	on	on
off	on	off	on

Important Product Safety Information **Refractory Ceramic Fiber Product**

Warning:

The Repair Parts list designates parts that contain refractory ceramic fibers (RCF). RCF has been classified as a possible human carcinogen. When exposed to temperatures above 1805°F, such as during direct flame contact, RCF changes into crystalline silica, a known carcinogen. When disturbed as a result of servicing or repair, these substances become airborne and, if inhaled, may be hazardous to your health.

AVOID Breathing Fiber Particulates and Dust

Precautionary Measures:

Do not remove or replace RCF parts or attempt any service or repair work involving RCF without wearing the following protective gear:

1. A National Institute for Occupational Safety and Health (NIOSH) approved respirator
 2. Long sleeved, loose fitting clothing
 3. Gloves
 4. Eye Protection
- Take steps to assure adequate ventilation.
 - Wash all exposed body areas gently with soap and water after contact.
 - Wash work clothes separately from other laundry and rinse washing machine after use to avoid contaminating other clothes.
 - Discard used RCF components by sealing in an airtight plastic bag. RCF and crystalline silica are not classified as hazardous wastes in the United States and Canada.

First Aid Procedures:

- If contact with eyes: Flush with water for at least 15 minutes. Seek immediate medical attention if irritation persists.
- If contact with skin: Wash affected area gently with soap and water. Seek immediate medical attention if irritation persists.
- If breathing difficulty develops: Leave the area and move to a location with clean fresh air. Seek immediate medical attention if breathing difficulties persist.
- Ingestion: Do not induce vomiting. Drink plenty of water. Seek immediate medical attention.

WARNING

Service on this boiler should be undertaken only by trained and skilled personnel from a qualified service agency. Inspections should be performed at intervals specified in this manual. Maintain manual in a legible condition.

Keep boiler area clear and free of combustible materials, gasoline and other flammable vapors and liquids.

Do not place any obstructions in boiler room that will hinder flow of combustion and ventilation air.

- A. General.** Inspection and service should be conducted annually. Turn off electrical power and gas supply while conducting service or maintenance. Follow instructions TO TURN OFF GAS TO APPLIANCE. See Figure 16.

CAUTION

Label all wires prior to disconnection when servicing controls. Wiring errors can cause improper and dangerous operation. Verify proper operation after servicing.

- B. Low Water Cutoff** (if so equipped). Follow instructions provided with low water cutoff.

- C. Inspect Vent System.** See Figure 22.

1. Remove obstructions in vent pipe and chimney.
2. Remove soot accumulations with wire brush and vacuum.
3. Repair or replace deteriorated vent pipe and vent accessories.
4. Provide proper support. Repair sags, particularly in horizontal sections.
5. Repair leaking joints.

- D. Inspect Boiler Flue Passages** for blockage or soot accumulation. See Figure 22.

1. Remove vent pipe, vent damper, blocked vent switch and draft hood.
2. Remove sheet metal screws securing Jacket Top Panel. Lift panel and rotate about safety relief valve piping until top of boiler is exposed. If piping or wall prevent full rotation of top panel for access to canopy, cut slot into safety relief valve opening and remove top panel.
3. Remove carriage bolts securing Canopy to Section Assembly. For high efficiency models (CG-DH) remove flue baffles.
4. Using flashlight, examine all flue passageways.
 - a. If passageways are free of soot and obstruction, replace canopy, secure and seal.
 - b. If passageways need cleaning, remove burners as described in Paragraph E. Using long handle wire or bristle flue brush and vacuum, brush

flueways thoroughly from top of boiler as illustrated in Figure 22. Replace canopy and seal.

5. Install flue baffles (if used).
6. Install new gasket material (See Section IX: Repair Parts). Install canopy. Secure with carriage bolts.
7. Install Jacket Top Panel, Draft Hood, Blocked Vent Switch, Vent Damper, and vent pipe.

- E. Clean Main Burners and Firebox.**

1. To remove burners for cleaning, changing orifices, or repairs:
 - a. Remove Jacket Front Panel.
 - b. Disconnect pilot tubing at gas valve.
 - c. Disconnect 3-wire plug at the gas valve.
 - d. 40mm burners only. Remove injection shield assembly, where used. See Figure 26.
 - e. Remove wires to flame roll-out switch.
 - f. Remove the burner access panel.
 - g. Mark the location of the pilot main burner on the manifold if the marking on manifold is missing or obliterated.
 - h. Hold burner at throat. Lift front of burner to clear orifice. Burner which holds pilot can only be removed by lifting the burner adjacent to its right first.

Table 9: Pilot Burner Location

Boiler Model	Main Burner with Pilot Bracket *		Pilot Burner Located Between Main Burners *	
	1 Inch	40mm	1 Inch	40mm
CG20D	1	1	1 & 2	---
CG30D	1	1	1 & 2	1 & 2
CG40D	2	2	2 & 3	2 & 3
CG50D	3	2	3 & 4	2 & 3
CG60D	4	3	4 & 5	3 & 4
CG70D	6	3	6 & 7	3 & 4
CG80D	7	4	7 & 8	4 & 5
CG90D	8	4	8 & 9	4 & 5
CG100D	9	5	9 & 10	5 & 6

* Main burners are numbered left to right as viewed from front of boiler.

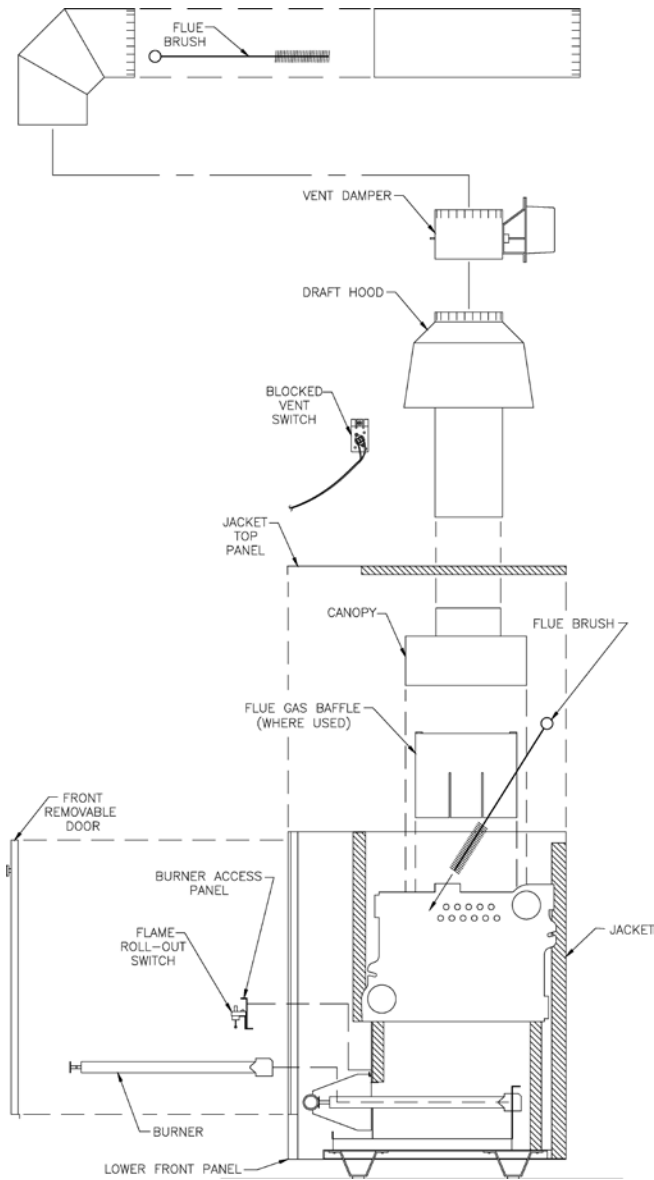

Figure 22: Flueway Cleaning

2. Brush top of burners with a soft bristle brush. See Figure 23. Vacuum burners.
3. Check orifices. Drilled passageways must be free of lint or dirt.
4. Vacuum tip of Pilot Burner.
5. Clean firebox by vacuuming. Exercise care not to damage base insulation.
6. Install burners by reversing procedure used to remove burners. Make sure burner with pilot assembly is in same location as original installation - see Table 9.

Check burners to see that they are located properly in slot at rear of burner tray, see Figure 23. Reinstall injection shield assembly (40mm burners only, where used) and burner access panel. Reconnect flame roll-out switch wires, pilot gas supply, thermocouple lead or pilot lead.

7. Connect pilot gas supply, igniter/sensor wire, and ground wire at Boiler Control.
8. Install Burner Access Panel. Connect Flame Rollout Switch wires.

F. Check Operation. Follow steps C through J from Section VII: System Start-up.

G. Removal or replacement of pilot assembly or pilot assembly parts. If pilot assembly, sensor or pilot orifice need replacing, remove main burner with pilot using procedure described in Paragraph E.

1. To replace orifice spud:
 - a. Disconnect pilot tubing. The Honeywell Q3481B pilot orifices are spud type retained by the compression fitting. Replace with desired orifice spud. See Key No. 5B in Repair Parts Section.
 - b. Reconnect pilot tubing and check for leaks.
2. To replace complete pilot assembly.
 - a. Remove machine screw holding pilot burner to pilot bracket.
 - b. Disconnect pilot piping.
 - c. Disconnect all other leads to pilot.
 - d. Select pilot assembly with identical model number, reconnect leads and pilot tubing - re-secure to pilot bracket.
3. To adjust or check spark gap between electrode and hood on Honeywell Q3481B pilot.
 - a. Use round wire gauge to check spark gap.
 - b. Spark gap should be 1/8 inch for optimum performance.
4. Reinstall main burner following procedure described in Paragraph E.

H. Lubrication. There are no parts requiring lubrication by service technician or owner. Circulator bearings are water lubricated.

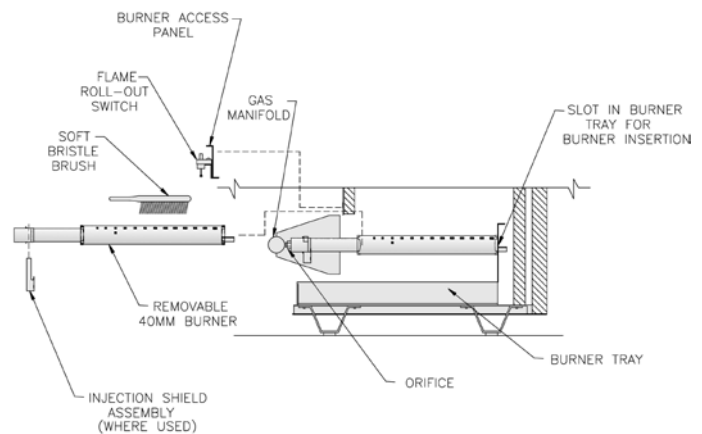

Figure 23: Burner Cleaning and Installation

X. Troubleshooting

A. BEFORE TROUBLESHOOTING

The following pages contain trouble shooting tables for use in diagnosing control problems. When using these tables the following should be kept in mind:

1. This information is only meant to be used by a professional heating technician as an aid in diagnosing boiler problems.
2. Where applicable, follow all precautions outlined in Section VII on page 18.
3. In general, these tables assume that there are no loose or miswired electrical connections. Before using these tables inspect all electrical connections on the boiler to make sure that they are tight. Also, check the wiring on the boiler against the wiring

diagram in Figures 11 and 12. Ensure that incoming 120 Vac power polarity is correct and that the boiler is properly grounded. Further, ensure that the control power supply is 24 VAC (minimum 18 VAC to maximum 30 VAC) and polarity is correct.

4. All controls on the CG-D Series are tested at least once in the manufacturing process and a defective control or component is generally the least likely cause. Before replacing a component, try to rule out all other possible causes.
5. When checking voltage across wiring harness pins be careful not to insert the meter probes into the pins. Doing so may damage the pin, resulting in a loose connection when the harness is reconnected.

Operating Mode Parameters	
<i>StA</i>	Status (see Status Numbers)
<i>bT</i>	Boiler Temperature
<i>SP</i>	Operating Setpoint (Outdoor Reset)
<i>HL</i>	High Limit Setpoint
<i>HdF</i>	High Limit Differential Setpoint
<i>tT</i>	Heat Request Status
<i>dh</i>	DHW Heat Request Status
<i>FLA</i>	Flame Current
<i>run</i>	Run Time Hours
<i>CYC</i>	Boiler Cycles
<i>Err</i>	Error (see Error Numbers)

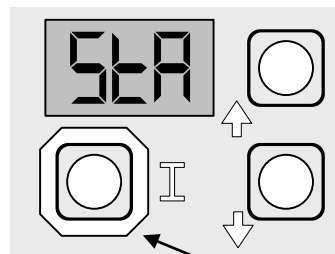

Press "I" key on the control to change from one parameter to the next. Each setting will alternate between display code (for example *StA*) and value.

When *Err* (error) is shown:

Value	Description
4	Flame current lower than threshold
6	Flame Out of Normal Sequence
18	Electronics Failure
23	Flame Sensed During Pre-purge
32	Temperature Sensor Failure
55	Damper Failed to Open
56	Damper Failed to Close
57	Flame Rod Shorted to Ground
58	AC Line Frequency
59	Line Voltage Error
60	Thermostat input higher than threshold
61	Line Voltage Unstable
63	Soft Lockout – Recycles Exceeded
64	Soft Lockout – Internal Failure

Possible *StA* (status) values:

Value	Description
1	Standby
4	Pre-purge
6	Spark
7	Flame Proving
8	Running
10	Retry/Recycle Delay
13	Soft Lockout
14	Hard Lockout
15	Waiting for Limit to Close
16	Flame Present Out of Sequence
17	Self Test
18	Waiting for Damper to Open
19	Waiting for Damper to Close
20	Damper Failure to Open
21	Damper Failure to Close

Figure 27: Using Control Display to Troubleshoot CG-D Series Boiler

B. USE CONTROL DISPLAY *Err* (ERROR) NUMBER TO DIRECT TROUBLESHOOTING EFFORTS

If the control detects an error it will flash “*Err*” (error) followed by a number. Use this number to identify the boiler problem and corrective action in the table below. If there is no *Err* display proceed to Paragraph C:

Display	Status	Recommended Corrective Action
Blank	Boiler or Control is not powered	No 120 Vac Power at boiler, check breaker and wiring between breaker panel and boiler
<i>Err</i> 4	Flame Current Lower than Threshold	Check pilot assembly. Refer to Troubleshooting Section, C6.
<i>Err</i> 6	Flame Sensed Out of Normal Sequence	Flame sensed out of normal sequence (before opening gas valve or after closing gas valve). Check gas valve for proper operation.
<i>Err</i> 18	Electronics Failure	Cycle power to control. Replace control if problem persists.
<i>Err</i> 23	Flame Sensed During Pre-purge	Flame sensed during post-purge (before gas valve signaled open). Check the gas valve for proper operation. Replace gas valve if problem persists.
<i>Err</i> 32	Temperature Sensor Failure	Temperature sensor or interface failure (open or short connection, increased connection resistance, dual sensor mismatch) or control hardware failure. <ul style="list-style-type: none"> - Check sensor is securely attached to control P7 connector. - If secure, replace sensor. - If problem persists, replace control.
<i>Err</i> 55	Damper Failed to Open	Atmospheric Damper End Switch failed to close (end switch contacts stuck open). Refer to Troubleshooting Section, C5.
<i>Err</i> 56	Damper Failed to Close	Damper open. Voltage should not be present on P6-5. Control, vent damper or wire harness is defective. While the <i>Err</i> 56 is displayed by the control, perform the following tasks: <ul style="list-style-type: none"> • Remove the call for heat (adjust thermostat or remove wire from TT terminals). • Check for 24Vac between P6-5 and ground. • If voltage not present, attempt to start boiler again. • If 24Vac is present, unplug the vent damper harness from control. • With wire harness unplugged, check for 24Vac between P6-5 (on Control) and ground. • If voltage present, replace the control. • If voltage not present, failed vent damper or wiring harness. • Check wiring harness for shorts or mis-wiring. Replace if defective. • If harness not defective, replace vent damper.
<i>Err</i> 57	Flame Rod Shorted to Burner Ground	Flame Rod shorted to burner ground, this can result from excessive flue gas condensation. <ul style="list-style-type: none"> - Check for excessive condensate. Dry pilot. Adjust setpoint higher. - Check for loose or damaged ignition wire.
<i>Err</i> 58	AC Line Frequency	Error AC Signal is too noisy or frequency is incorrect. Check supply voltage. Check Sensor for Common shorted to ground.
<i>Err</i> 59	Line Voltage Error	AC voltage out of specification high or low. Check supply voltage.
<i>Err</i> 60	Thermostat Input Higher than Threshold	Check thermostat wiring.
<i>Err</i> 61	Line Voltage Unstable	Possibly too many heavy loads switching on and off cause erratic supply voltage. Check supply voltage.
<i>Err</i> 63	Soft Lockout – Maximum Recycles Exceeded	Maximum number of recycles exceeded. Refer to Troubleshooting Section, C6.
<i>Err</i> 64	Soft Lockout – Internal Failure	The electronics has detected an error. This can be caused by an actual controller internal fault or wiring fault: <ul style="list-style-type: none"> - Check vent damper, cycle power with vent damper disconnected. If error is cleared, reconnect the vent damper and refer to Recommended Corrective Action listed under <i>Err</i> 20, damper failed to open. - Check pilot assembly, - If problem persists, replace the control.

C. USE 5EA (STATUS) NUMBER TO GUIDE TROUBLESHOOTING

The control will flash “5EA” followed by a number. Use this number to identify the boiler problem in the table below:

1. Boiler and Circulator Off

Display / Status	Recommended Corrective Action
<p>5EA 1 Standby Burner off Circulator off</p>	<p>The boiler has not detected a call for heat ($\epsilon\epsilon = \text{OFF}$ and $dh = \text{OFF}$).</p> <p>Check that the thermostat:</p> <ul style="list-style-type: none"> - When a thermostat call for heat is detected control display “$\epsilon\epsilon$” will show “ON” - Make sure thermostat is calling for heat and contacts (including appropriate zone controls) are closed. Check for loose connection. <p>Check the DHW demand:</p> <ul style="list-style-type: none"> - When a domestic call for heat is detected “dh” will show “ON” - Make sure the DHW aquastat contact is closed. Check for loose connection.

2. Circulator is On, But Boiler is Off

Display / Status	Recommended Corrective Action
<p>5EA 1 Circulator Pre-purge Burner off Circulator on</p>	<p>The boiler is warm and circulator is providing residual boiler heat to building:</p> <p>Check boiler temperature</p> <ul style="list-style-type: none"> - The boiler will not start until boiler water temperature is less than the Setpoint (SP) minus differential (dF) - If boiler water temperature is higher than Start Temperature ($5\epsilon_{-}$, default = 140 F) and the Circulator Pre-purge (PP_{-}, default = 2 minutes) time has not expired, boiler start will be delayed until water temperature drops or time expires. To permit the boiler to start sooner increase Start Temperature parameter. Refer to Operation Section for additional information.

3. Boiler is On, But Circulator is Off

Display / Status	Recommended Corrective Action
<p>5EA 8 Burner on Circulator off</p>	<p>Domestic Hot Water (DHW) Priority Forcing Circulator Off</p> <ul style="list-style-type: none"> - When there is a DHW heat request wired to the Control’s DHW terminal the System Circulator will be “forced off” for the duration of the DHW heat request. When the DHW heat request ends the System Circulator “force off” is removed, the circulator can respond normally. When the Priority Time, (PE_{-}) Parameter is set to “OFF” the System Circulator is not “forced off” for a DHW call for heat. <p>Wiring / Circulator Issue:</p> <ul style="list-style-type: none"> - Check wiring for loose connection, miswiring - Check circulator

4. Circulator is On But Damper is Not Open

Display / Status	Recommended Corrective Action
<p>5EA 15 Limit Open</p>	<p>Waiting for Limit to Open.</p> <ul style="list-style-type: none"> - Check Blocked Vent Switch, in the event of a blocked vent or poor draft condition, the blocked vent switch will open interrupting power to control P5-4. The main burners will be extinguished immediately and the circulator will remain on until the thermostat is turned off. The source of blockage must be corrected by trained and skilled personnel from a qualified service agency before resetting switch. Blocked Vents are caused by a collapsed chimney resulting in full or partial blockage, chimney cross sectional area too small, height insufficient or cold chimney causing sustained poor draft. Always follow the recommendations in Section I, Figure 1 and Section V, Venting. - Check Flame Rollout Switch, in the event of excessive blockage of the boiler section flue passageways is developed the flame rollout switch will open interrupting power to control P5-4. The main burners will be extinguished immediately and the circulator will remain on until the thermostat is turned off. If the flame rollout switch is activated, do not attempt to place the boiler in operation. The source of the blockage must be corrected and the identical flame rollout switch replaced by trained and skilled personnel from a qualified service agency. - Check External Limit.

5. Circulator is On But Damper is Not Open

Display / Status	Recommended Corrective Action
<p>5LR 20 Damper Failed to Open</p>	<p>The control is waiting for the damper to open. Damper end switch has failed to close (end switch contact is stuck open). Combustion can never take place unless the damper blade is in the fully open position. Check the following:</p> <ul style="list-style-type: none"> - During status "5LR 18" or "5LR 20" the control terminal "P6 - 5" (yellow wire) is energized. - Check for loose connection between control and vent damper, check damper harness. - Check for obstruction in path of damper - When damper is open (end switch closed) control terminal "P6 - 2" should receive power from the vent damper. - Place jumper between control terminal P6-5 and P6-2. If error 55 does not clear, replace control. - Defective harness or vent damper.

6. Circulator is On, Damper is Open But Boiler Fails to Start

Display / Status	Description
<p>5LR 10 Retry / Recycle Delay</p>	<p>The Boiler is in "Retry Delay":</p> <ul style="list-style-type: none"> - The burner failed to light (no flame signal). After a 5 minute delay, Control will attempt to light the burner again. There is no limit to the number of retries. <p>Recycle Delay</p> <ul style="list-style-type: none"> - The burner loses flame during running mode, ("5LR 8"). After a 10 second delay, Control will attempt to light the burner again. If the burner loses flame during running mode, "5LR 8" during the next six recycles, Control will progress to a soft lockout.
<p>5LR 13 Soft Lockout</p>	<p>When a soft lockout occurs, boiler will shut down. Boiler automatically restarts once condition that caused the lockout is corrected and the one-hour time delay is completed. Boiler can be restarted sooner than the time delay by using Adjustment Mode and selecting the reset button (see Adjustment Mode instructions) or by cycling power. Soft Lockout is caused by one of the following:</p> <ul style="list-style-type: none"> - Maximum Recycles Exceeded – The burner lost flame during running mode, "5LR 8" six times in a row. Refer to recommended corrective actions on next page to help determine the cause of the problem. - Err 54, Internal Failure, refer to Error code listing for recommended corrective action. - Err 23, Flame sensed during post-purge (before gas valve signaled open). Check the gas valve for proper operation. Replace gas valve if problem persists.
<p>5LR 14 Hard Lockout</p>	<p>When a hard lockout occurs boiler shuts down.</p>
<p>5LR 16 Flame Out of Sequence</p>	<p>If flame is detected in pre-purge Control goes to Flame Out of Sequence Before trial, "5LR 15" and "Err 23" is reported. The control gives a flame 10 seconds to disappear. If flame goes away, control resumes heating cycle from the beginning. If it doesn't "Err 23" is cleared and "Err 5" is reported. When flame is off control goes to Soft Lockout and "Err 5" is cleared. Check the gas valve for proper operation.</p>

6. Circulator is On, Damper is Open But Boiler Fails to Start (continued)

Display / Status	Recommended Corrective Action
<p>5EA 10 Retry / Recycle Delay</p> <p>5EA 13 Soft Lockout</p>	<p>1. No Spark</p> <p>a. Can you hear sparking while 5EA 5 is displayed?</p> <ul style="list-style-type: none"> - If there is no spark noise replace the control. <p>b. If you can hear spark noise check the following:</p> <ul style="list-style-type: none"> - Loose connection in ignition cable or ground wire - Continuity of ignition cable - Break in ignition cable insulation - Loose ground connection - Break in pilot ceramic insulator - Incorrect pilot spark gap
	<p>2. No Pilot Flame</p> <p>a. If pilot does not light check the following:</p> <ul style="list-style-type: none"> - All manual gas valves are open - Supply tubing is not plugged, kinked or leaking - Gas line pressures are good - Gas line is purged of air - Pilot orifice is not plugged (pilot gas is flowing) - Condensate quenching pilot <p>Note: It may be necessary to recycle the “call for heat” more than once to clear the pilot supply tubes of air.</p> <p>b. If no gas flow check the following:</p> <ul style="list-style-type: none"> - 24 volts across PV and MV/PV at gas valve, if voltage ok replace defective gas valve - Check for break in wiring harness to gas valve - 24 volts across control connector P5-2 and P5-5, if no voltage at control replace defective control
	<p>3. Spark does Not Stop When Pilot Lights</p> <p>If the spark does not stop when the pilot lights check the following:</p> <ul style="list-style-type: none"> - Loose connection in ignition cable or ground wire - Continuity of ignition cable - Clean flame rod - Pilot electrode porcelain cracked - Pilot flame covers flame rod and is steady and blue, if not adjust pilot flame - Low gas pressure at gas valve inlet - Defective control
	<p>4. Main Flame Does Not Light</p> <p>If the main burners do not light check the following:</p> <ul style="list-style-type: none"> - Check orifice size and/or blockage - 24 volts across control terminals P5-8 and P5-5? If no voltage while in 5EA 7 defective control. - 24 volts across MV and MV/PV at gas valve? Check for break in wiring harness to gas valve - Defective gas valve

XI. Repair Parts

All CG-D™ Series repair parts may be ordered through New Yorker Boiler Company, Inc. or its authorized distributors.

Should you require assistance in locating a New Yorker Distributor in your area, or have questions regarding the availability of New Yorker products or repair parts, please contact:

New Yorker Boiler Company, Inc.
P.O. Box 10
Hatfield, Pennsylvania 19440-0010
Attn: Customer Service Department
www.newyorkerboiler.com

Section Assembly and Canopy Assembly	36
Base Assembly	38
Manifold and Main Burners	
1 Inch Main Burners	40
40mm Main Burners	42
Pilot Burner and Gas Valve	44
Jacket Assembly, Complete	45
Controls and Trim	46
Draft Hood and Vent Damper	46

Key No.	Description	Part Number	CG-D MODEL								
			20	30	40	50	60	70	80	90	100
1	Cast Iron Section Assembly (Complete)	6171702	1	---	---	---	---	---	---	---	---
		6171703	---	1	---	---	---	---	---	---	---
		6171704	---	---	1	---	---	---	---	---	---
		6171705	---	---	---	1	---	---	---	---	---
		6171706	---	---	---	---	1	---	---	---	---
		6171707	---	---	---	---	---	1	---	---	---
		6171708	---	---	---	---	---	---	1	---	---
		6171709	---	---	---	---	---	---	---	1	---
		6171710	---	---	---	---	---	---	---	---	1
2	Flue Baffle (CG30DH Thru CG60DH Models Only)	71106001	---	2	3	4	5	---	---	---	---
3	Canopy Assembly	61117022	1	---	---	---	---	---	---	---	---
		611170302	---	1	---	---	---	---	---	---	---
		611170402	---	---	1[a]	---	---	---	---	---	---
		100310-01	---	---	1[b]	---	---	---	---	---	---
		611170502	---	---	---	1	---	---	---	---	---
		611170602	---	---	---	---	1[a]	---	---	---	---
		100310-02	---	---	---	---	1[b]	---	---	---	---
		6111706010	---	---	---	---	1[c]	---	---	---	---
		611170702	---	---	---	---	---	1	---	---	---
		611170802	---	---	---	---	---	---	1[a]	---	---
		100310-03	---	---	---	---	---	---	1[b]	---	---
		611170902	---	---	---	---	---	---	---	1	---
		611171002	---	---	---	---	---	---	---	---	1[a]
		100310-04	---	---	---	---	---	---	---	---	1[b]
Footnote to Canopy Assembly: [a] - 1" Burners only [b] - 40mm Burners only [c] - CG60DH Model only											
4	Cerafelt Sealing Strip ½" x 1" x 10' (Canopy for Section Assembly)	6206001	1	1	1	1	1	1	1	1	1
5	Carriage Bolt ¼" - 20 x 1"	80860115	2	2	2	2	2	2	2	2	2
	Flat Washer, ¼"	80860603									
	Nut, Hex ¼" - 20	80860407									

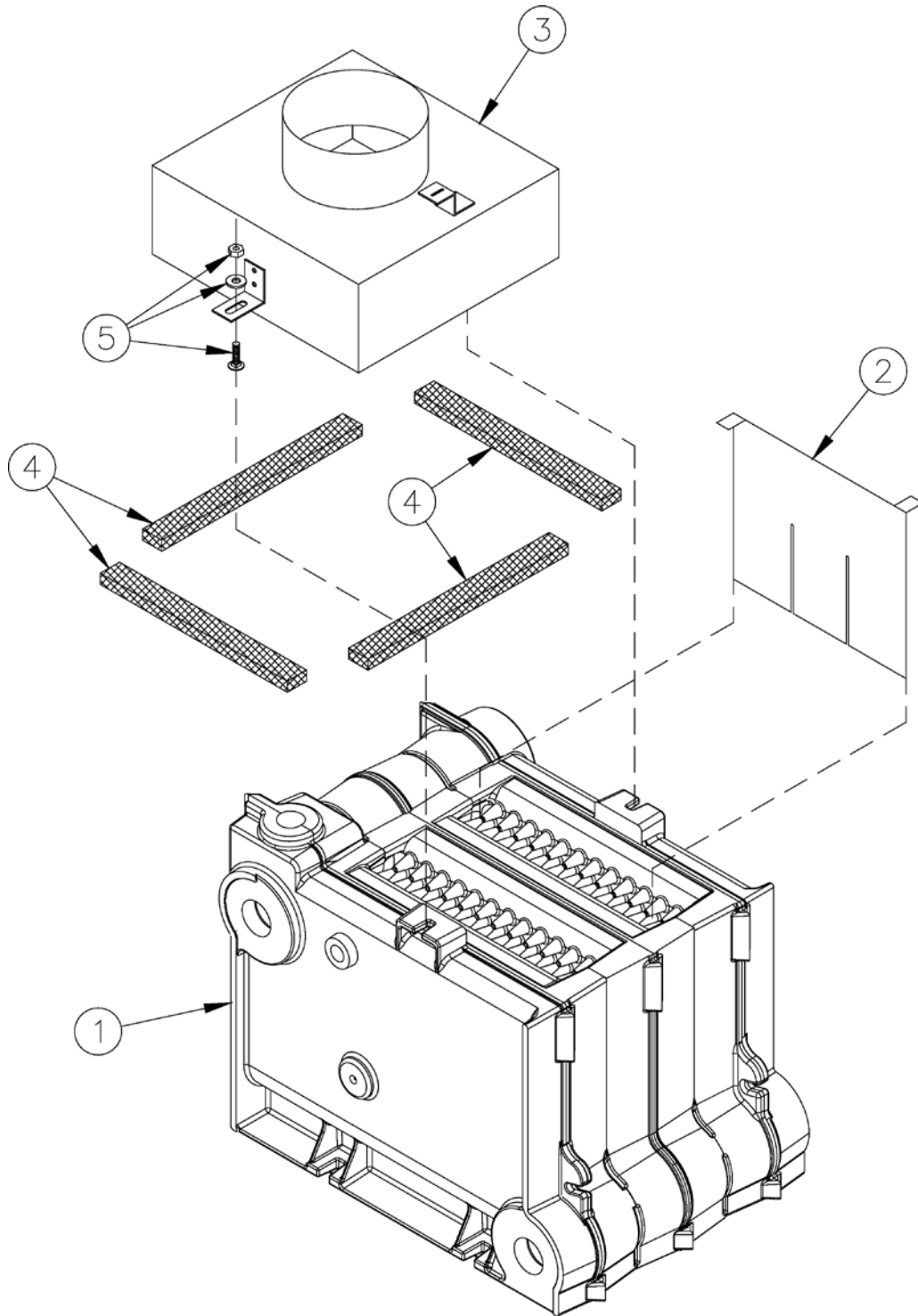

Section Assembly and Canopy Group

Key No.	Description	Part Number	CG-D MODEL								
			20	30	40	50	60	70	80	90	100
6	Base Tray	718600291	1	---	---	---	---	---	---	---	---
		718600391	---	1	---	---	---	---	---	---	---
		718600491	---	---	1	---	---	---	---	---	---
		718600591	---	---	---	1	---	---	---	---	---
		718600691	---	---	---	---	1	---	---	---	---
		718600791	---	---	---	---	---	1	---	---	---
		718600891	---	---	---	---	---	---	1	---	---
		718600991	---	---	---	---	---	---	---	1	---
		718601091	---	---	---	---	---	---	---	---	1
7	Base Wrapper	718600211	1	---	---	---	---	---	---	---	---
		718600311	---	1	---	---	---	---	---	---	---
		718600411	---	---	1	---	---	---	---	---	---
		718600511	---	---	---	1	---	---	---	---	---
		718600611	---	---	---	---	1	---	---	---	---
		718600711	---	---	---	---	---	1	---	---	---
		718600811	---	---	---	---	---	---	1	---	---
		718600911	---	---	---	---	---	---	---	1	---
		718601011	---	---	---	---	---	---	---	---	1
8	Base End Insulation	720601	2	2	2	2	2	2	2	2	2
9	Base Rear Insulation	72060025	1	---	---	---	---	---	---	---	---
		72060035	---	1	---	---	---	---	---	---	---
		72060045	---	---	1	---	---	---	---	---	---
		72060055	---	---	---	1	---	---	---	---	---
		72060065	---	---	---	---	1	---	---	---	---
		72060075	---	---	---	---	---	1	---	---	---
		72060085	---	---	---	---	---	---	1	---	---
		72060095	---	---	---	---	---	---	---	1	---
		72060105	---	---	---	---	---	---	---	---	1
10	Base Front Panel Assembly	618600241	1	---	---	---	---	---	---	---	---
		618600341	---	1	---	---	---	---	---	---	---
		618600441	---	---	1	---	---	---	---	---	---
		618600541	---	---	---	1	---	---	---	---	---
		618600641	---	---	---	---	1	---	---	---	---
		618600741	---	---	---	---	---	1	---	---	---
		618600841	---	---	---	---	---	---	1	---	---
		618600941	---	---	---	---	---	---	---	1	---
		618601041	---	---	---	---	---	---	---	---	1
11	Base Leg Assembly	6186001	4	4	4	4	4	4	4	4	4
12	Base Leg	71860021	4	4	4	4	4	4	4	4	4
13	Nylon Glide	8186006	4	4	4	4	4	4	4	4	4

Key No.	Description	Part Number	CG-D MODEL								
			20	30	40	50	60	70	80	90	100
14	Burner Access Panel	718600261	1	---	---	---	---	---	---	---	---
		718600361	---	1	---	---	---	---	---	---	---
		718600461	---	---	1	---	---	---	---	---	---
		718600561	---	---	---	1	---	---	---	---	---
		718600661	---	---	---	---	1	---	---	---	---
		718600761	---	---	---	---	---	1	---	---	---
		718600861	---	---	---	---	---	---	1	---	---
		718600961	---	---	---	---	---	---	---	1	---
		718601061	---	---	---	---	---	---	---	---	1
15	Self-Tapping Screw ¼ - 20 x ½	80860700	20	20	20	20	20	21	21	21	21
16	Self-Tapping Screw 5/16 - 18 x 1¼	80860717	4	4	4	4	4	4	4	4	4
17	Flat Washer 5/16", USS	80860601	4	4	4	4	4	4	4	4	4
18	Hex Lock Nut 5/16 - 18	80860464	4	4	4	4	4	4	4	4	4
19	Cerafelt Sealing Strip ½" x 2" x 10' (Section Assembly to Base)	6206002	1	1	1	1	1	1	1	1	1

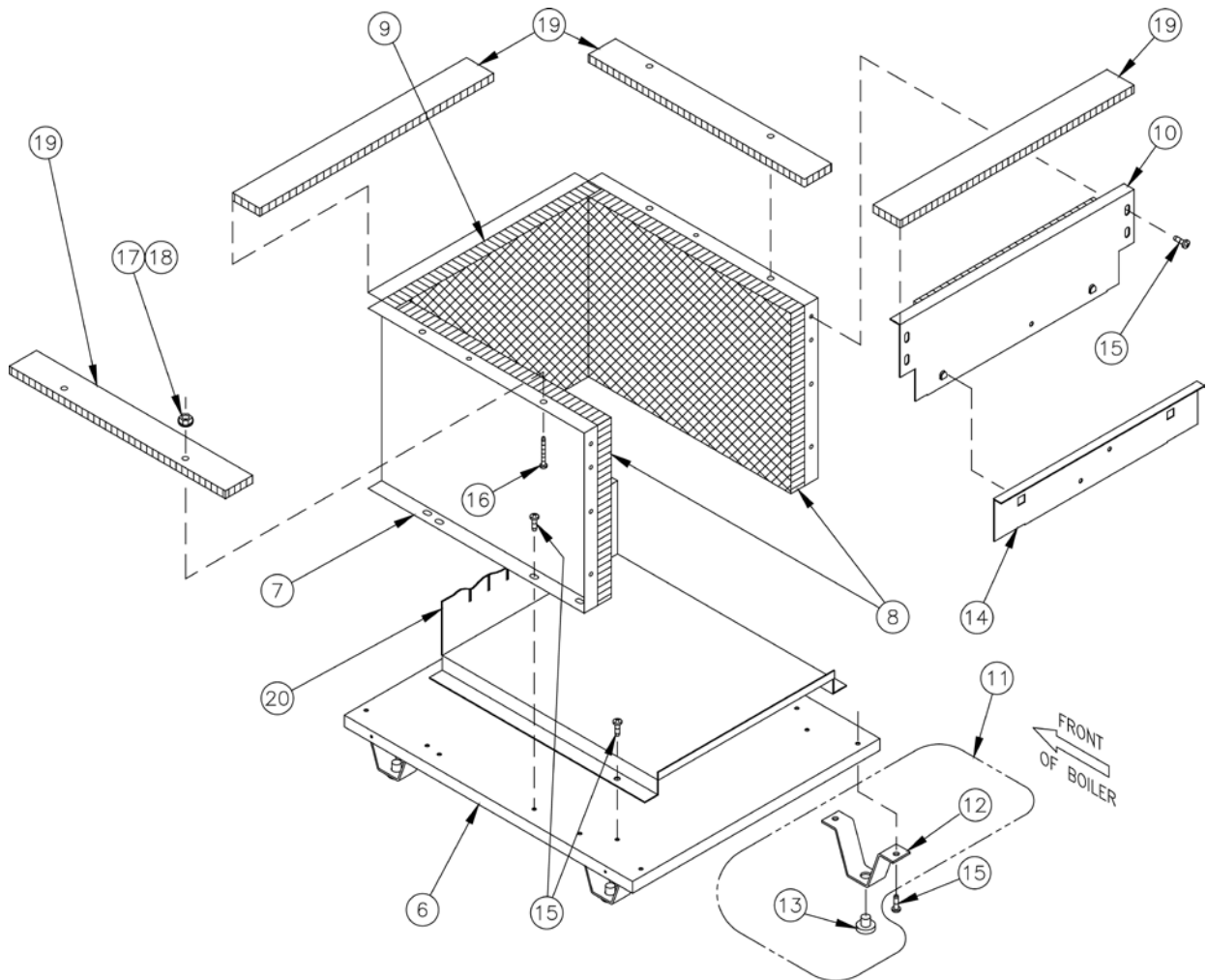

Key No.	Description	Part Number	CG-D MODEL									
			20	30	40	50	60	70	80	90	100	
Burner Tray, Main Burners and Manifold (1 Inch Main Burners Only)												
20	Burner Tray/Burner Tray Assembly	718600205	1	---	---	---	---	---	---	---	---	---
		100307-01	---	1	---	---	---	---	---	---	---	---
		718600405	---	---	1	---	---	---	---	---	---	---
		718600505	---	---	---	1	---	---	---	---	---	---
		718600605	---	---	---	---	1	---	---	---	---	---
		100307-02	---	---	---	---	---	1	---	---	---	---
		100307-03	---	---	---	---	---	---	1	---	---	---
		718600905	---	---	---	---	---	---	---	1	---	---
		100307-04	---	---	---	---	---	---	---	---	---	1
21	Main Burner w/Slotted Orifice Bracket	8236119	1	2	4	6	8	11	13	15	17	
22	Main Burner w/60° Pilot Bracket - EI, Natural & LP Gas	8236118	1	1	1	1	1	1	1	1	1	
23	Manifold	82219021	1	---	---	---	---	---	---	---	---	
		82219031	---	1	---	---	---	---	---	---	---	
		82219041	---	---	1	---	---	---	---	---	---	
		82219051	---	---	---	1	---	---	---	---	---	
		82219061	---	---	---	---	1	---	---	---	---	
		82219071	---	---	---	---	---	1	---	---	---	
		82219081	---	---	---	---	---	---	1	---	---	
		82219091	---	---	---	---	---	---	---	1	---	
		82219101	---	---	---	---	---	---	---	---	1	
Burner Gas Orifice - Natural Gas, Sea Level to 2000 Ft.												
24	Main Burner Orifice #45 (Pink)	822711	---	3	5	7	9	---	---	---	---	
	Main Burner Orifice #47 (White)	822710	2	---	---	---	---	12	14	16	18	
Burner Gas Orifice - LP Gas, Sea Level to 2000 Ft.												
24	Main Burner Orifice 1.25mm (Purple)	822705	2	---	5	7	9	---	---	---	---	
	Main Burner Orifice #55 (Green)	822708	---	3	---	---	---	---	---	---	---	
	Main Burner Orifice 3/64" (Blue)	822704	---	---	---	---	---	12	14	16	18	

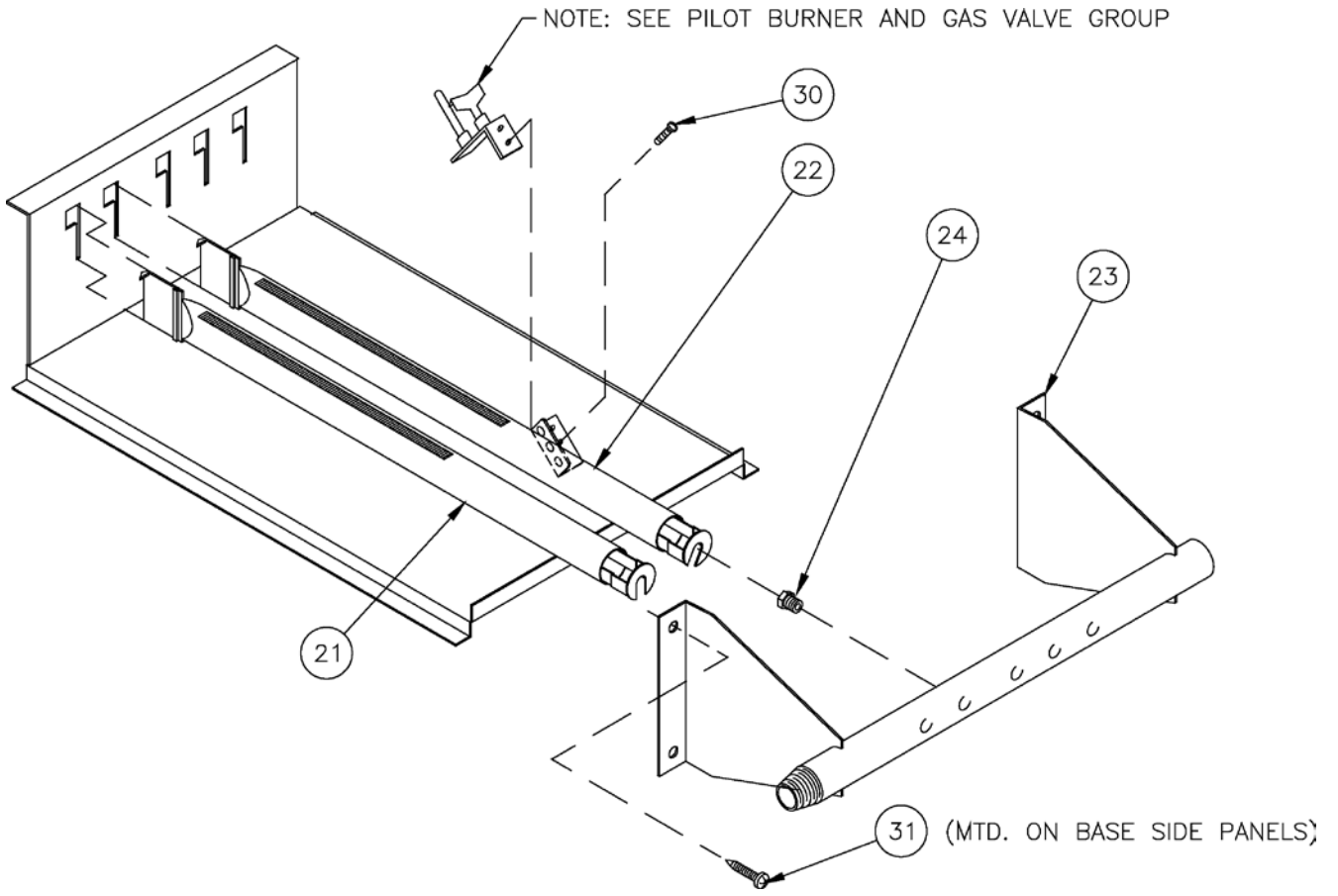

**Manifold and Main Burners
(1 Inch Main Burners)**

Key No.	Description	Part Number	CG-D MODEL									
			20	30	40	50	60	70	80	90	100	
Burner Tray, Main Burners and Manifold (40mm Main Burners Only)												
25	Burner Tray/Burner Tray Assembly	100308-01	---	1	---	---	---	---	---	---	---	---
		71806047	---	---	1	---	---	---	---	---	---	---
		71806057	---	---	---	1	---	---	---	---	---	---
		71806067	---	---	---	---	1	---	---	---	---	---
		71806077	---	---	---	---	---	1	---	---	---	---
		100308-02	---	---	---	---	---	---	1	---	---	---
		718600906	---	---	---	---	---	---	---	1	---	---
		100308-03	---	---	---	---	---	---	---	---	---	1
26	Main Burner	8236135	---	1	2	3	4	5	6	7	8	
27	Main Burner w/41° Pilot Bracket	8236136	---	1	1	1	1	1	1	1	1	
28	Manifold	82219032	---	1	---	---	---	---	---	---	---	
		82219042	---	---	1	---	---	---	---	---	---	
		82219052	---	---	---	1	---	---	---	---	---	
		82219062	---	---	---	---	1	---	---	---	---	
		82219072	---	---	---	---	---	1	---	---	---	
		82219082	---	---	---	---	---	---	1	---	---	
		82219092	---	---	---	---	---	---	---	1	---	
		82219102	---	---	---	---	---	---	---	---	1	
Burner Gas Orifice - Natural Gas, 2000-5000 Ft. USA Only												
29	Main Burner Orifice #39	822727	---	2	3	---	---	---	---	---	---	
	Main Burner Orifice #38	822720	---	---	---	4	5	6	7	8	9	
Burner Gas Orifice - LP Gas, 2000-5000 Ft. USA Only												
29	Main Burner Orifice #53	822722	---	2	3	4	5	6	7	8	9	
Burner Gas Orifice, Natural Gas, 5000-9000 Ft. USA Only												
29	Main Burner Orifice #41	822729	---	2	3	---	---	---	---	---	---	
	Main Burner Orifice #40	822728	---	---	---	4	5	6	7	8	9	
Burner Gas Orifice, LP Gas, 5000-9000 Ft. USA Only												
29	Main Burner Orifice #54	822734	---	2	---	---	---	---	---	---	---	
	Main Burner Orifice #53	822722	---	---	3	4	5	6	7	8	9	
30	MS, Phillips Head w/Captive Lockwasher, #10-32 x ¼"	80860874	---	2	2	2	2	2	2	2	2	
31	Self Tapping Screw, Phillips Pan Head, ¼-20 x ½"	80860700	---	4	4	4	4	4	4	4	4	
32	Injection Shield Assembly	71860 -- 62	---	A/R	A/R	A/R	A/R	A/R	A/R	A/R	A/R	
		Footnotes to Injection Shield Assembly: --: Number of cast iron sections A/R: As Required										

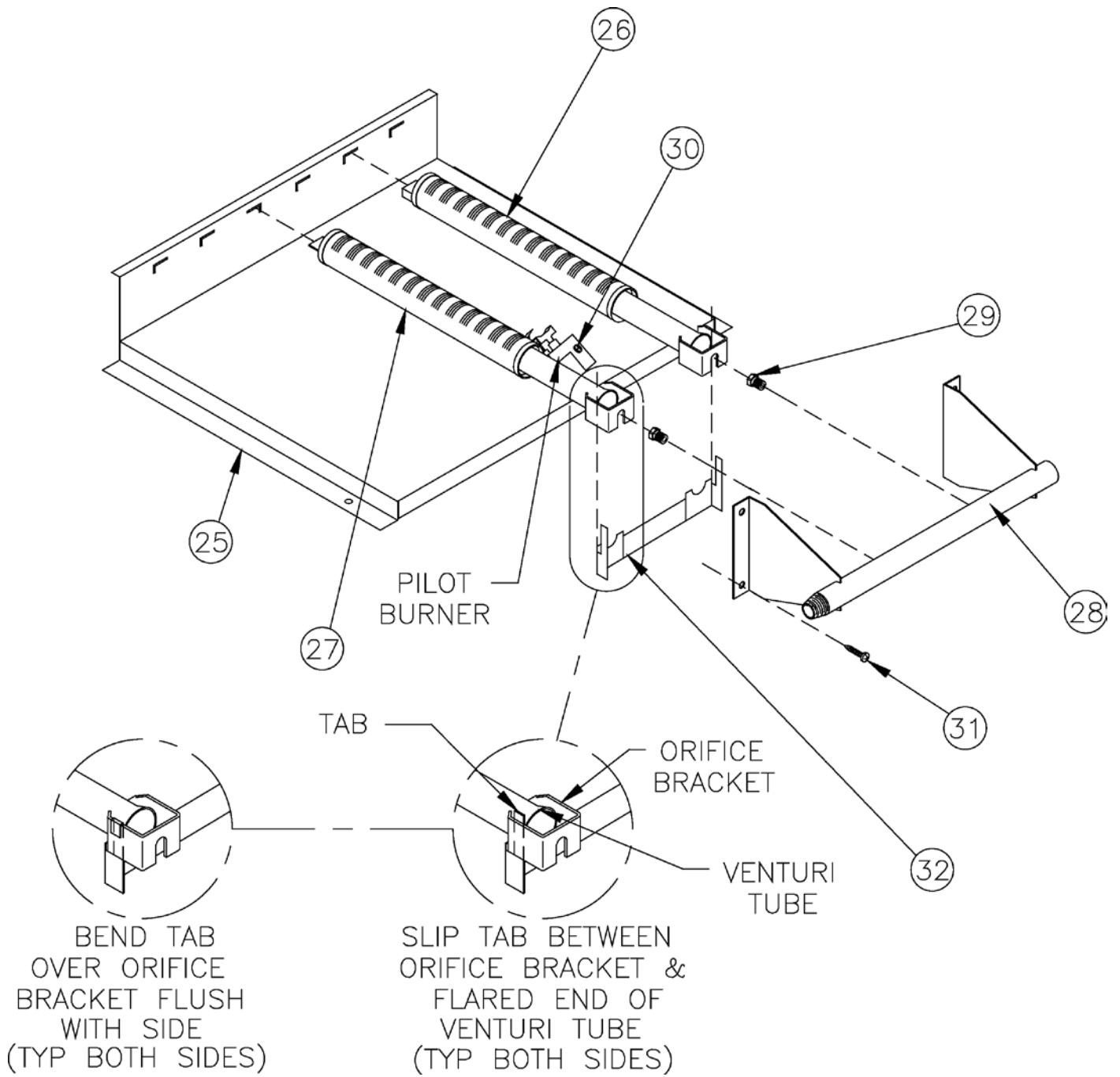

**Manifold and Main Burners
 (40mm Main Burners)**

Key No.	Description	Part Number	CG-D MODEL								
			20	30	40	50	60	70	80	90	100
Pilot Burner and Gas Valve, Natural & LP Gas											
33	Pilot Burner, Honeywell Q3481B1206 (Nat. Gas)	103704-01	1	1	1	1	1	1	1	1	1
	Pilot Burner, Honeywell Q3481B1420 (LP)	103705-01	1	1	1	1	1	1	1	1	1
33A	Pilot Orifice, Honeywell NE22 (Nat. Gas)	Included with Pilot Burner	1	1	1	1	1	1	1	1	1
	Pilot Orifice, Honeywell KR14 (LP)		1	1	1	1	1	1	1	1	1
33B	Compression Fitting, 7/16" Hex x 5/8" Lg.	Included w/ Pilot Burner & Gas Valve	1	1	1	1	1	1	1	1	1
33C	Compression Fitting, Honeywell 386449-4 1/4" OD x 1/4" C.C.		1	1	1	1	1	1	1	1	1
34	Gas Valve, Honeywell VR8204C3007 (Nat. Gas)	81660145	1	1	1	1	1	---	---	---	---
	Gas Valve, Honeywell VR8304P4306 (Nat. Gas)	81660161	---	---	---	---	---	1	1	1	1
	Gas Valve, Honeywell VR8204C3015 (LP)	81660146	1	1	1	1	1	---	---	---	---
	Gas Valve, Honeywell VR8304P4314 (LP)	81660160	---	---	---	---	---	1	1	1	1
35	Pilot Tubing 1/4" OD x 30" Lg. Aluminum	8236122	1	1	1	1	---	---	---	---	---
	Pilot Tubing 1/4" OD x 40" Lg. Aluminum	8236123	---	---	---	---	1	1	---	---	---
	Pilot Tubing 1/4" OD x 48" Lg. Aluminum	8236042	---	---	---	---	---	---	1	1	1
36	Ground Wire Assembly	103776-01	1	1	1	1	1	1	1	1	1

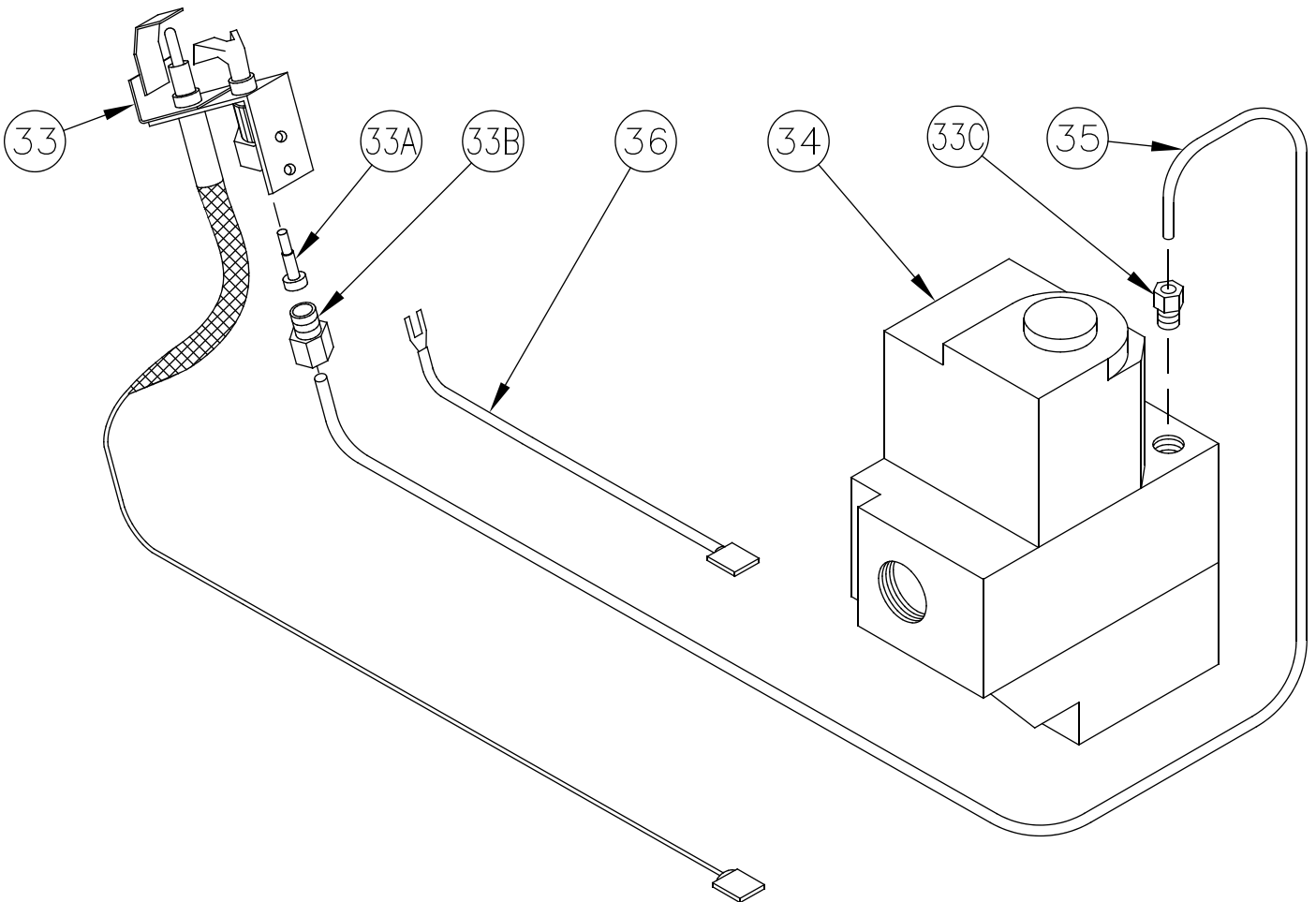

Key No.	Description	Part Number	CG-D MODEL								
			20	30	40	50	60	70	80	90	100
Jacket Assembly, Complete											
37	Jacket Assembly, Complete	100292-01	1	---	---	---	---	---	---	---	---
		100294-02	---	1	---	---	---	---	---	---	---
		100294-03	---	---	1	---	---	---	---	---	---
		100294-04	---	---	---	1	---	---	---	---	---
		100294-05	---	---	---	---	1	---	---	---	---
		100294-06	---	---	---	---	---	1	---	---	---
		100294-07	---	---	---	---	---	---	1	---	---
		100294-08	---	---	---	---	---	---	---	1	---
		100294-09	---	---	---	---	---	---	---	---	1

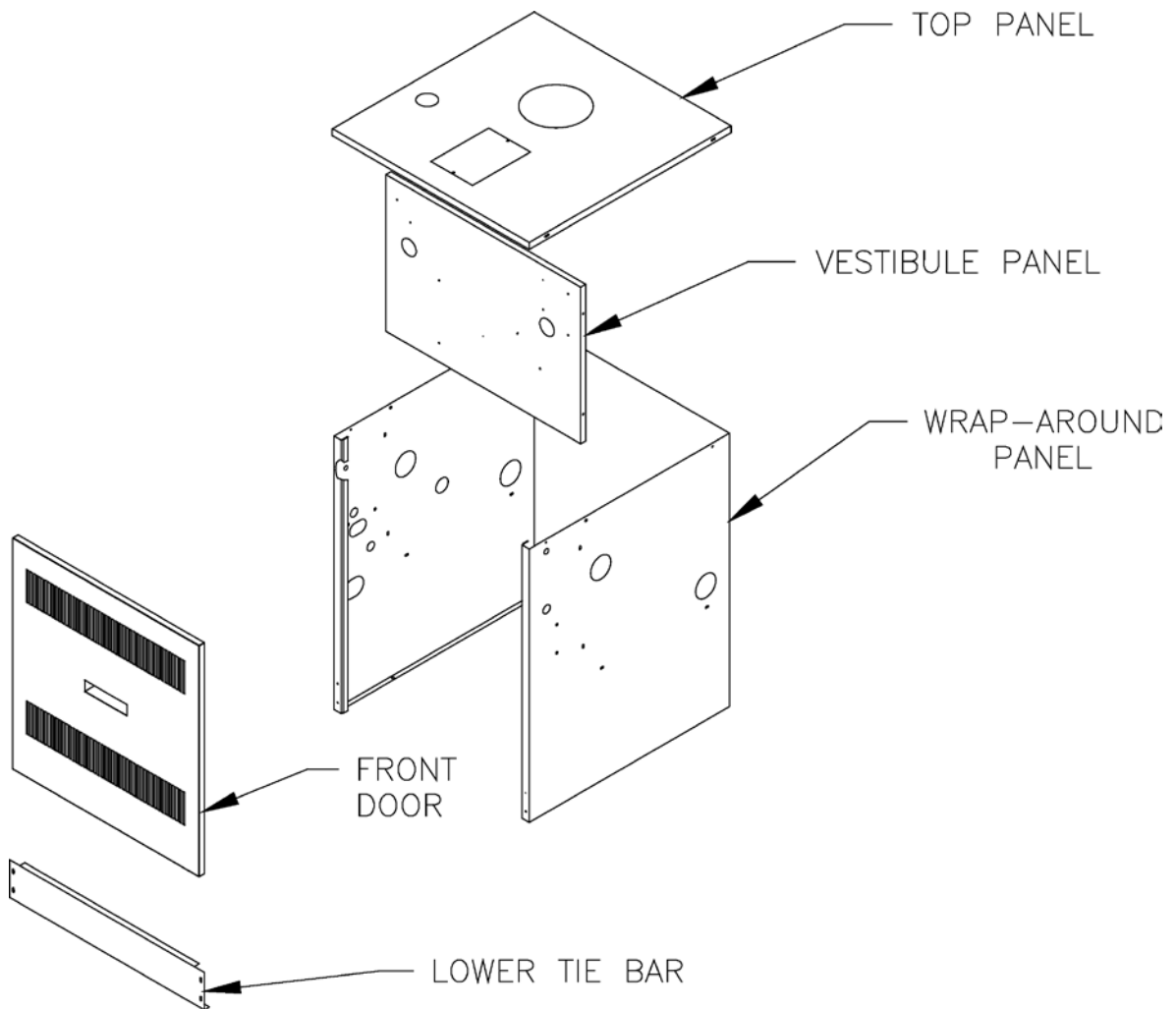

Key No.	Description	Part Number	CG-D MODEL									
			20	30	40	50	60	70	80	90	100	
Controls and Trim												
38	Temperature / Pressure Gauge	100282-01	1	1	1	1	1	1	1	1	1	1
39	Drain Valve, Conbraco 35-302-03	806603061	1	1	1	1	1	1	1	1	1	1
40	Safety Relief Valve, 30 psi, 3/4 NPT Conbraco 10-408-05	81660319	1	1	1	1	1	1	1	1	1	1
41	Flame Rollout Switch	80160044	1	1	1	1	1	1	1	1	1	1
42	Flame Rollout Switch Mounting Bracket	7186018	N/A	1	1	1	1	1	1	1	1	1
43	Blocked Vent Switch Replacement Assembly	6016066	1	1	1	1	1	1	1	1	1	1
44	Limit Rated Temperature Sensor, 48" Lg., Honeywell 50001464-005	102296-01	1	1	1	1	1	1	1	1	1	1
45	1/2" Immersion Well, Honeywell 123869A	80160456	1	1	1	1	1	1	1	1	1	1
46	Temperature Sensor Clip, Honeywell 32002656-001	102422-01	1	1	1	1	1	1	1	1	1	1
47	Boiler Control, Atmospheric Draft, Honeywell S9361A2072	103966-01	1	1	1	1	1	1	1	1	1	1
48	Control Panel	103659-01	1	1	1	1	1	1	1	1	1	1
49	Junction Box, 4" x 4" x 1½"	8136259	1	1	1	1	1	1	1	1	1	1
50	Junction Box Cover	8136180	1	1	1	1	1	1	1	1	1	1
51	Transformer, 40 VA, Honeywell AT140D1297	102516-01	1	1	1	1	1	1	1	1	1	1
52	Circulator w/Gaskets and Hardware, Taco 007	8056182	1	1	1	1	1	1	1	1	1	1
Draft Hood, Vent Reducer and Vent Damper (Natural or LP/Propane Gas)												
53	Draft Hood	8116067	1	1	---	---	---	---	---	---	---	---
		8111702	---	---	1	---	---	---	---	---	---	---
		8111703	---	---	---	1	1	---	---	---	---	---
		8111704	---	---	---	---	---	1	1	---	---	---
		8111705	---	---	---	---	---	---	---	---	1	1
54	Vent Damper - 4" Dia.	102284-01	1	1	---	---	---	---	---	---	---	---
	Vent Damper - 5" Dia.	102284-02	---	---	1	---	---	---	---	---	---	---
	Vent Damper - 6" Dia.	102284-03	---	---	---	1	1	---	---	---	---	---
	Vent Damper - 7" Dia.	102284-04	---	---	---	---	---	1	1	---	---	---
	Vent Damper - 8" Dia.	102284-05	---	---	---	---	---	---	---	---	1	1
55	Vent Reducer, 4" x 3"	8116164	1	---	---	---	---	---	---	---	---	---

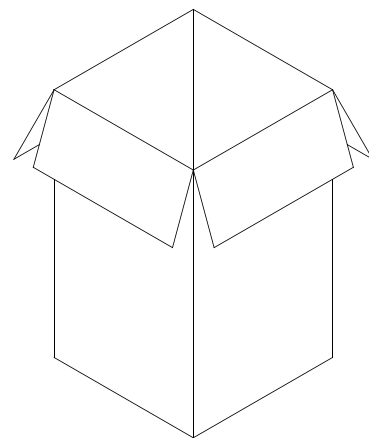
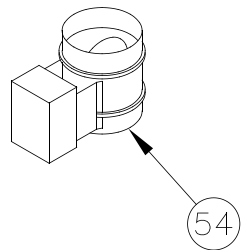
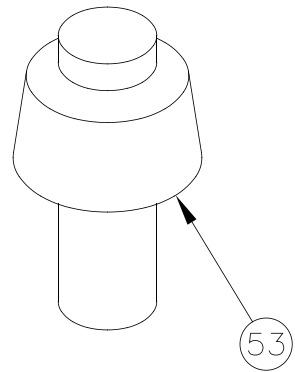
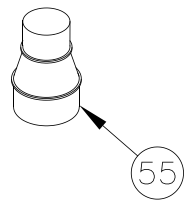
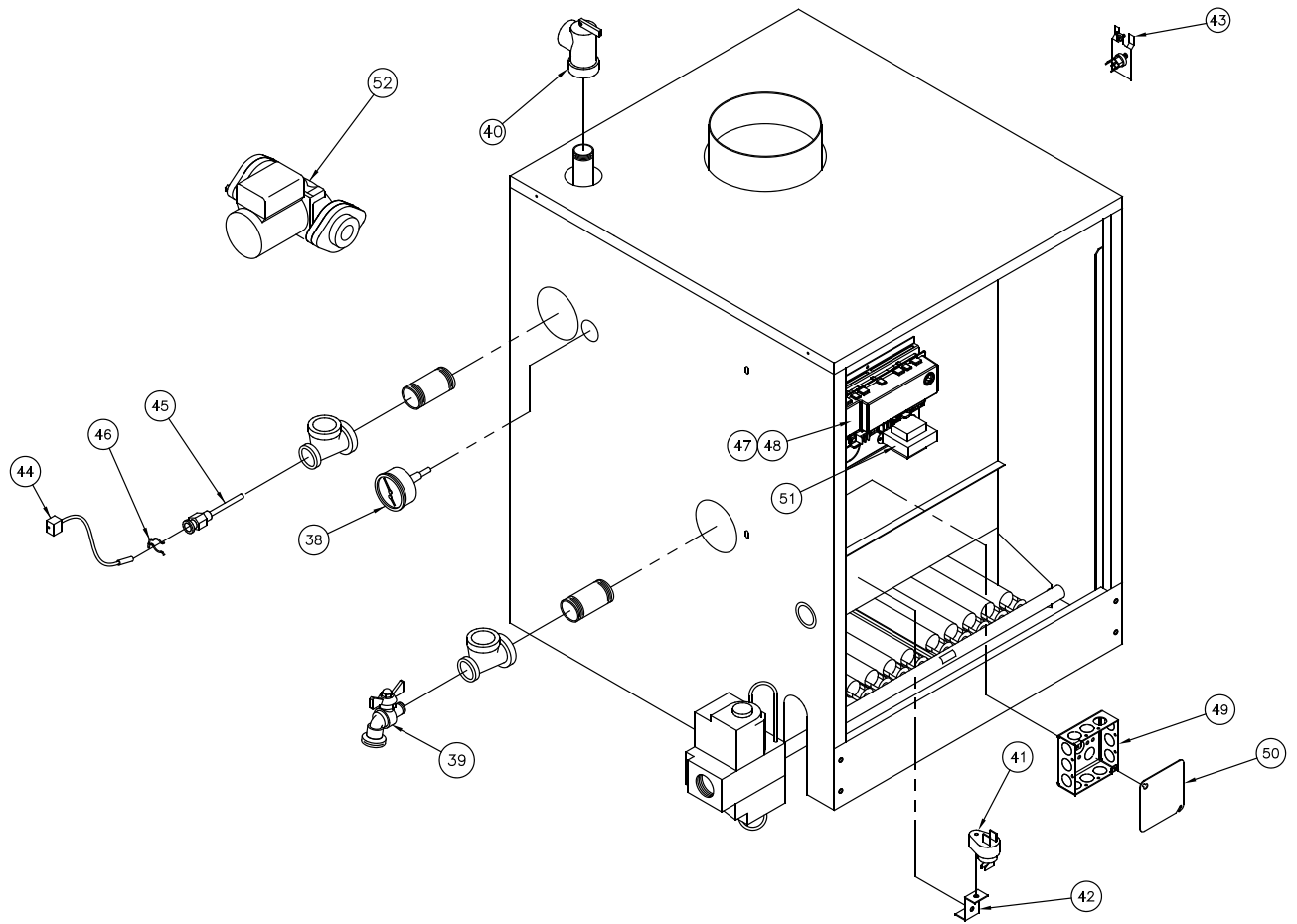

VENT DAMPER CARTON

DRAFT HOOD CARTON

NEW YORKER BOILER CO., INC.

Limited Warranties

For Residential Cast Iron and Steel Boilers

By this Warranty Statement New Yorker Boiler Co., Inc. ("New Yorker"), issues limited warranties subject to the terms and conditions stated below. These limited warranties apply to residential cast iron and steel water boilers labeled with the New Yorker® brand which are sold on or after March 1, 2004.

ONE YEAR LIMITED WARRANTY

One Year Limited Warranty for Residential Water Boilers New Yorker warrants to the original consumer purchaser at the original installation address that its residential cast iron and steel water boilers will be free from defects in material and workmanship under normal usage for a period of one year from the date of original installation. In the event that any defect in material or workmanship is found during the one year period following the date of installation, New Yorker will, at its option, repair the defective part or provide a replacement free of charge, F.O.B. its factory.

WC BOILER FIVE YEAR LIMITED WARRANTY

Five Year Pressure Vessel Limited Warranty for WC™ Residential Water Boilers New Yorker warrants to the original consumer purchaser at the original installation address that the pressure vessel of the boiler will be free of defects in material and workmanship under normal usage for a period of five years following the date of installation. In the event that any defect in material or workmanship is found during the five year period following the date of installation, New Yorker will, at its option, repair the defective pressure vessel or provide a replacement free of charge, F.O.B. its factory.

LIFETIME LIMITED WARRANTY

For all gas/oil-fired residential boilers, New Yorker warrants to the original consumer purchaser at the original installation address that the heat exchanger of the boiler will be free of defects in material and workmanship under normal usage for the lifetime of the original consumer purchaser. In the event that any defect in material or workmanship is found during the ten year period following the date of installation, New Yorker will, at its option, repair the defective pressure vessel or provide a replacement free of charge, F.O.B. its factory. In the event that any defect in material or workmanship is found after the tenth year following the date of installation, New Yorker will provide a replacement pressure vessel upon payment by the original consumer purchaser of an amount equal to a percentage of the then current retail price of the model boiler involved (or, in the event that such model is not then in production, the most comparable model then in production), as follows:

		Service Charge as a % of Retail Price																							
Years in Service	1-5	6	7	8	9	10	11	12	13	14	15	16	17	18	19	20	21	22	23	24	25+				
WC Boilers	N/C	100																							
Water Boilers	No Charge	5	10	15	20	25	30	35	40	45	50	55	60	65	70	75									
Steam Boilers	No Charge	100																							

EXCEPTIONS AND EXCLUSIONS

- Components Manufactured by Others** - following the expiration of the foregoing one year limited warranty, all component parts of a boiler which are manufactured by others (such as burners, burner controls, circulator, tankless water heater, and New Yorker Link) shall be subject only to the manufacturer's warranty, if any.
- Removal and Replacement Costs** - these warranties do not cover expenses of removal or reinstallation. The consumer purchaser will be responsible for the cost of removing and replacing any defective part and all labor and related materials connected therewith. Replacement parts will be invoiced to the distributor in the usual manner and will be subject to adjustment upon proof of defect.
- Proper Installation** - these warranties are conditioned upon the installation of the boiler in strict compliance with New Yorker's Installation, Operating and Service Instructions. New Yorker specifically disclaims any liability of any kind which arises from or relates to improper installation.
- Improper Use or Maintenance** - these warranties will not be applicable if the boiler is used or operated over its rated capacity, is installed for uses other than home heating, or is not maintained in accordance with New Yorker's Installation, Operating and Service Instructions and hydronics industry standards.
- Improper Operation** - these warranties will not be applicable if the boiler has been damaged as a result of being improperly serviced or operated, including but not limited to the following:

operated with insufficient water; allowed to freeze; subjected to flood conditions; or operated with water conditions and/or fuels or additives which cause unusual deposits or corrosion or on the pressure vessel or associated controls.

- Geographic Limitations** - these warranties apply only to boilers installed within the 48 contiguous United States.
- Installation Requirements** - in order for these warranties to be effective:
 - The boiler must be installed in a single or two-family residential dwelling. This warranty does not apply to boilers installed in apartments for commercial or industrial applications.
 - The boiler must be installed in strict compliance with New Yorker's Installation, Operating and Service Instructions by an installer regularly engaged in boiler installations.
 - Boiler sections must not have been damaged during shipment or installation.
 - The boiler must be vented in accordance with chimney recommendations set forth in New Yorker's Installation, Operating and Service Instructions.
- Exclusive Remedy** - New Yorker's obligation in the event of any breach of these warranties is expressly limited to the repair or replacement of any part found to be defective under conditions of normal use.
- Limitation of Damages Under no circumstances will New Yorker be liable for incidental, indirect, special or consequential damages of any kind under these warranties, including, without limitation, injury or damage to persons or property and damages for loss of use, inconvenience or loss of time.** New Yorker's liability under these warranties shall under no circumstances exceed the purchase price paid for the boiler involved. Some states do not allow the exclusion or limitation of incidental or consequential damages, so the above limitation or exclusion may not apply to you.
- Limitation of Warranty** - these limited warranties are given in lieu of all other express warranties and set forth the entire obligation of New Yorker with respect to any defect in a residential water boiler. New Yorker shall have no express obligations, responsibilities or liabilities of any kind, other than those set forth herein.

ALL APPLICABLE IMPLIED WARRANTIES, IF ANY, INCLUDING ANY WARRANTY OF MERCHANT ABILITY OR FITNESS FOR A PARTICULAR PURPOSE, ARE EXPRESSLY LIMITED DURATION TO A PERIOD OF ONE YEAR, EXCEPT THAT IMPLIED WARRANTIES, IF ANY, APPLICABLE TO THE PRESSURE VESSEL OF A RESIDENTIAL WATER BOILER SHALL BE LIMITED IN DURATION TO THE LESSER OF THE DURATION OF SUCH IMPLIED WARRANTY OR A PERIOD EQUAL TO THE TERM OF THE APPLICABLE EXPRESS WARRANTY

Some states do not allow limitations on how long an implied warranty lasts, so the above limitation may not apply to you.

PROCEDURE FOR OBTAINING WARRANTY SERVICE

Upon discovery of a condition believed to be related to a defect in material or workmanship covered by these warranties, the original consumer purchaser should notify the installer, who will in turn notify the distributor. If this action is not possible or does not produce a prompt response, the original consumer purchaser should write to New Yorker Boiler Co., Inc. at P.O. Box 10, Hatfield, PA 19440-0010, giving full particulars in support of the claim.

The original consumer purchaser is required to make available for inspection by New Yorker or its representatives the parts claimed to be defective and, if requested by New Yorker, to ship those parts prepaid to New Yorker at the above address for inspection or repair. In addition, the original consumer purchaser agrees to make all reasonable efforts to settle any disagreement arising in connection with any warranty claim before resorting to legal remedies in the courts.

THIS WARRANTY GIVES YOU SPECIFIC LEGAL RIGHTS AND YOU MAY ALSO HAVE OTHER RIGHTS WHICH VARY FROM STATE TO STATE.



New Yorker
RESIDENTIAL HEATING BOILERS