

Burnham® Series 3™

Gas Fired, Chimney Vented, Cast Iron Water Boiler

Fully Updated for D.O.E. 2012 Compliance!

- 84% AFUE
- Electronic ignition
- Equipped with IQ Control System™
- 70 – 280 MBH (7 sizes)
- Industry standard tapping locations, allows easy, direct replacement for thousands of existing boiler installations
- Solid, reliable, American-made cast iron heat exchanger can accept return water temps as low as 110°F
- Lifetime limited warranty

IQ control system

- Consists of the Intelligent Hydronic Control and IQ Option Panel



Intelligent Hydronic Control

- Combines aquastat, relay, and ignition functions into a single module
- Two customizable integrated switching relays for easy addition of additional heating zone or indirect water heater
- Energy saving “thermal purge”, which works by circulating residual warm water (140° or above) in the heating system before firing the boiler

IQ Option Panel

- Enables the easy plug & play installation of optional features such as outdoor reset, LWCO, and high limit



Optional Touchscreen

- LCD displays all boiler settings, diagnostics, and troubleshooting in sentences, not codes



Burnham®
by
U.S. Boiler Company



Series 3: Technical Information



Standard Equipment

- Insulated sleek, modern jacket
- Integrated draft diverter, damper and connector included
- Heavy gauge 1" and 1-1/2" base insulation
- Intelligent Hydronic Control – Simple self-diagnostic control system with 3-digit readout for status settings and errors
- IQ Option Panel, accepts plug & play IQ Option Cards for
 - Outdoor reset with DHW priority
 - Auto or manual reset low water cutoff
 - Auto or manual auxilliary high limit
- Step-opening redundant gas valve
- 110°F minimum return temperature rating
- Spark ignition with continuous retry
- User-friendly wiring with 120V J-box
- Taco 007 circulator with piping with wiring harness
- Cast iron section assembly
- Resettable blocked vent switch
- Boiler drain valve
- Cast iron supply manifold with safety relief valve tapping

Series 3 Ratings & Specifications

Model	AFUE%	Input (MBH)	DOE Heating Capacity (MBH)	Net AHRI (MBH)	Vent Size (Inches)	Approx. Shipping Weight. (lbs.)
303	84	70	59	51	4	254
304	84	105	89	77	5	301
305	84	140	119	103	6	353
306	84	175	149	130	6	405
307	84	210	178	155	7	464
308	84	245	208	181	7	514
309	84	280	208	207	8	564

* Add suffix "N" for natural gas, or suffix "L" for LP gas models
 All models certified for use from sea level to 10,000 feet in elevation. Outputs are reduced by 2% per 1,000 feet in elevations from 5,000 to 10,000 feet.
 All Series 3 boilers are shipped with 30 psi relief valves, MAWP is 50 psi.

Series 3 Dimensions & Connections

Model	Dimensions (inches)			Connections (inches)				Water Content (gal.)
	Width	Height	Depth	Supply	Return	Gas Valve	Relief Valve	
303	12-3/4	41	33	1-1/4	1-1/4	1/2	3/4	2
304	15-1/2	41	33	1-1/4	1-1/4	1/2	3/4	3
305	18-1/2	41	33	1-1/4	1-1/4	1/2	3/4	4
306	21-1/2	41	33	1-1/4	1-1/4	1/2	3/4	5
307	24-3/4	41	33	1-1/4	1-1/4	3/4	3/4	6
308	24-3/4	41	33	1-1/4	1-1/4	3/4	3/4	7
309	30-3/4	41	33	1-1/4	1-1/4	3/4	3/4	8

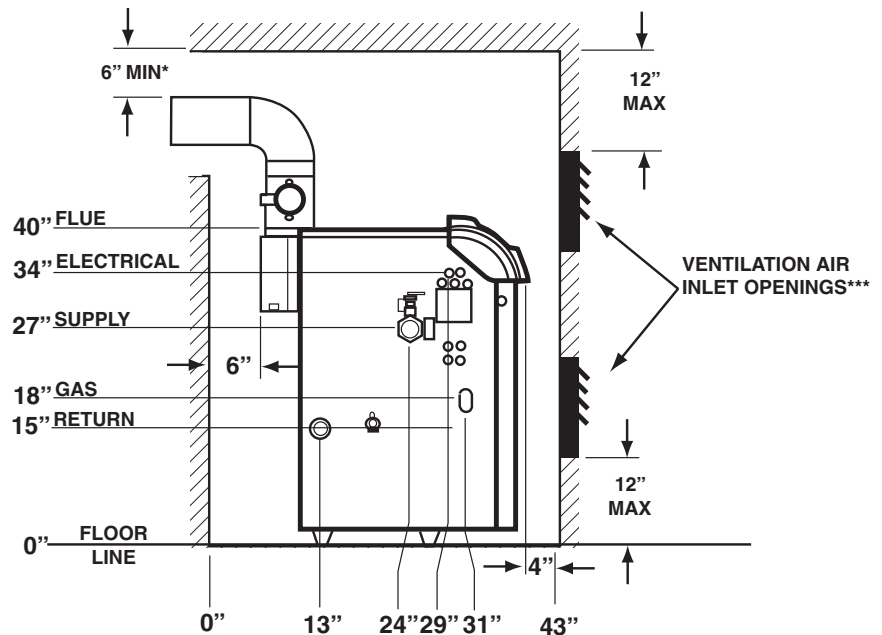
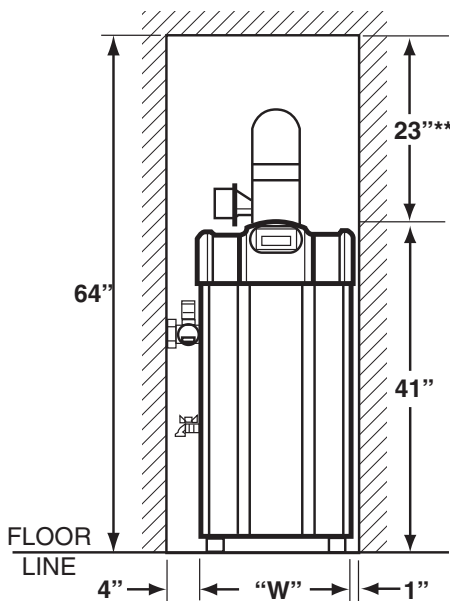

NOTES:

CAUTION: Chimney liner may be required by code requirements

* Minimal radial distance around vent pipe and breeching

** Add height required to maintain 6" clearance from all breeching components

*** Area of each opening 1 sq. inch for each 1,000 BTUH input - with minimum of 100 sq. inches. Height of opening should be half the width.